



50hz

CO₂

直膨式蒸发器
2026

蒸发器

- 商用蒸发器 : CEA	3
- 双出风蒸发器 : CED & CED Plus	25



CEA 蒸发器

商用蒸发器

CEA 系列商用蒸发器适用于冷库的冷冻冷藏需求。CEA 的高效内芯采用铝箔和 $\varnothing 12\text{mm}$ 内螺纹铜管，通过减少管容积来降低冷媒充注量，满足全球温室气体的减排需求。所有内芯均经过清洁和 80bar 保压测试。

01 白色喷涂的铝制外壳，有较高的防腐蚀和抗震性能。

02 电化霜的电加热管套有不锈钢管，固定于翅片和接水盘内，可隔绝水蒸气，且方便维护。

03 所有电器有效接地。电线均接入防护等级 IP65 的电器盒内。

04 可使用“Unit Selector Hybrid HISPANIA”选型软件查询样册以外的工况性能。



更多需求和信息请联系 Hispania。

CEA 2503 26 4D S1 2 3

翅片材料 (空白: 铝箔, 3: 不锈钢, GF: 金色铝箔)

外壳材料 (空白: 铝, 2: 不锈钢)

盘管材料 (空白: 铜, 1: 不锈钢)

化霜 (空白: 空气, D: 电, HG: 热氟, W: 水, HGD: 热氟&电, WD: 水&电)

片距 (mm)

面积 (m²)

风机数量

风机直径 (mm)

系列

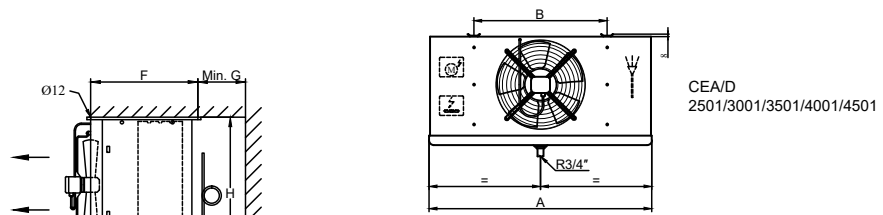

CEA/D
2501/3001/3501/4001/4501

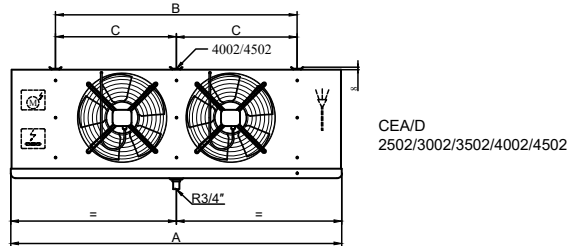

CEA/D
2502/3002/3502/4002/4502

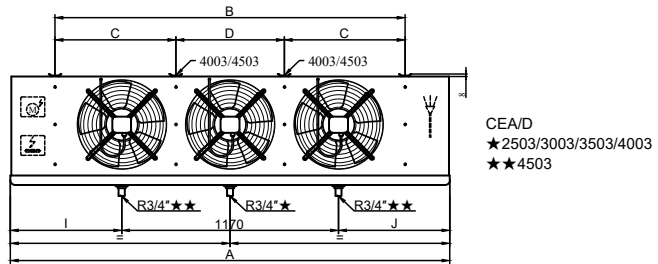

CEA/D
★2503/3003/3503/4003
★★4503

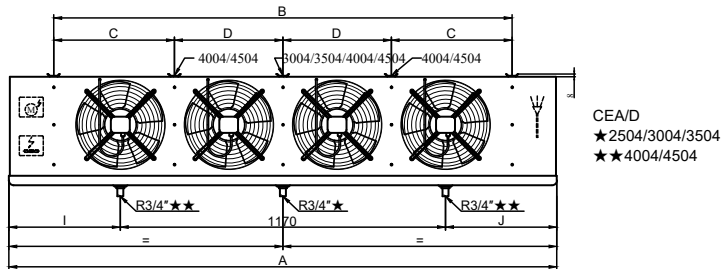

CEA/D
★2504/3004/3504
★★4004/4504

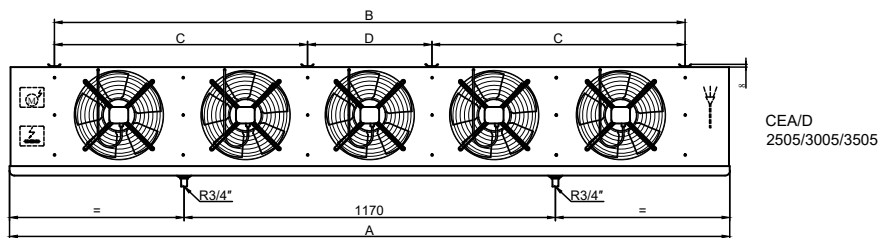

CEA/D
2505/3005/3505

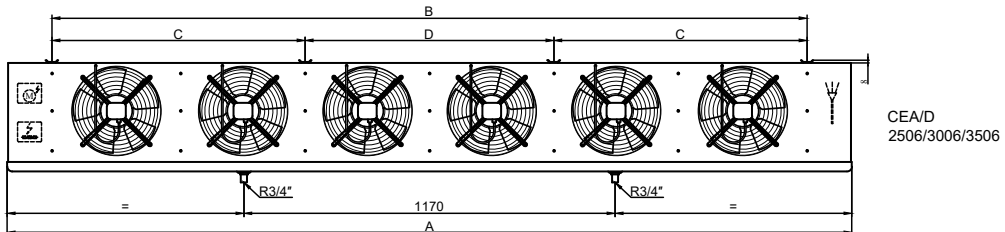

CEA/D
2506/3006/3506

型号	外形尺寸(mm)									
	A	B	C	D	E	F	I	J	G	H
CEA 2501...	702	420			325	375			200	350
CEA 2502...	1094	812			325	375			200	350
CEA 2503...	1486	1204			325	375			200	350
CEA 2504...	1878	1596	406	392	325	375			200	350
CEA 2505...	2270	1988	798	392	325	375			200	360
CEA 2506...	2662	2380	798	784	325	375			250	360
CEA 3001...	702	420			325	375			200	460
CEA 3002...	1094	812			325	375			200	460
CEA 3003...	1486	1204			325	375			250	460
CEA 3004...	1878	1596	406	392	325	375			250	460
CEA 3005...	2270	1988	798	392	325	375			300	470
CEA 3006...	2662	2380	798	784	325	375			300	470
CEA 3501...	702	420			455	507			200	460
CEA 3502...	1094	812			455	507			200	460
CEA 3503...	1486	1204			455	507			250	460
CEA 3504...	1878	1596	406	392	455	507			250	460
CEA 3505...	2270	1988	798	392	455	507			300	470
CEA 3506...	2662	2380	798	784	455	507			300	470
CEA 4001...	912	630			325	375			250	530
CEA 4002...	1486	1204	602		325	375			300	530
CEA 4003...	1878	1596	546	504	325	375			300	530
CEA 4004...	2662	2380	595	595	325	375			350	540
CEA 4501...	1094	812			325	375			300	600
CEA 4502...	1878	1596	798		325	375			300	600
CEA 4503...	2702	2380	798	784	325	375	746	786	350	610
CEA 4504...	3486	3164	798	784	325	375	746	786	350	610

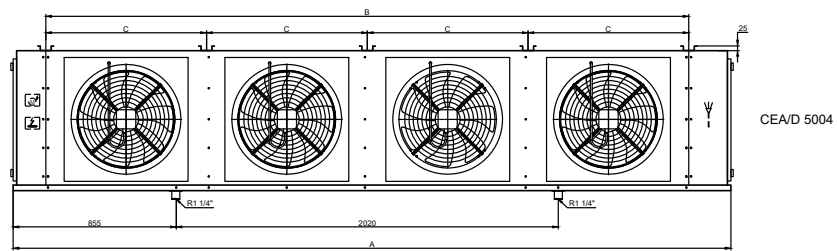
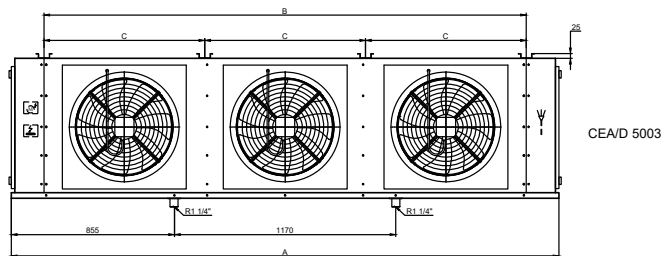
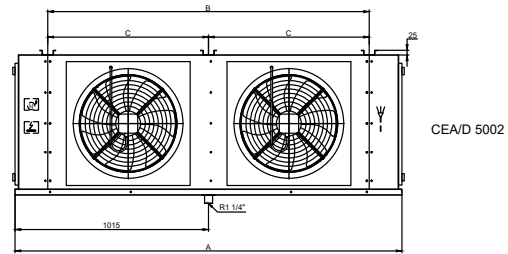
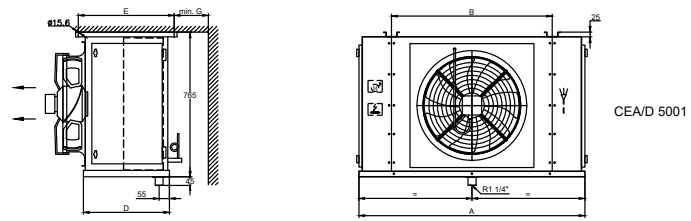

型号	外形尺寸(mm)					
	A	B	C	D	E	G
CEA 5001...(4 rows)	1195	845		455	507	400
CEA 5001...(6 rows)	1195	845		455	507	400
CEA 5001...(8 rows)	1195	845		560	610	400
CEA 5002...(4 rows)	2040	1690	845	455	507	400
CEA 5002...(6 rows)	2040	1690	845	455	507	400
CEA 5002...(8 rows)	2090	1690	845	560	610	400
CEA 5003...(4 rows)	2885	2535	845	455	507	450
CEA 5003...(6 rows)	2885	2535	845	455	507	450
CEA 5003...(8 rows)	2955	2535	845	560	610	450
CEA 5004...(4 rows)	3800	3380	845	455	507	450
CEA 5004...(6 rows)	3800	3380	845	489	541	450
CEA 5004...(8 rows)	3800	3380	845	560	610	450

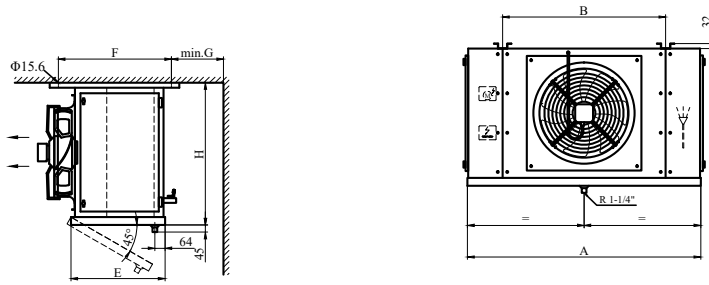

CEA
5501/6301/8001

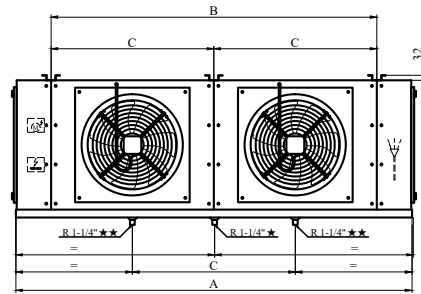

CEA
★5502
★★6302/8002

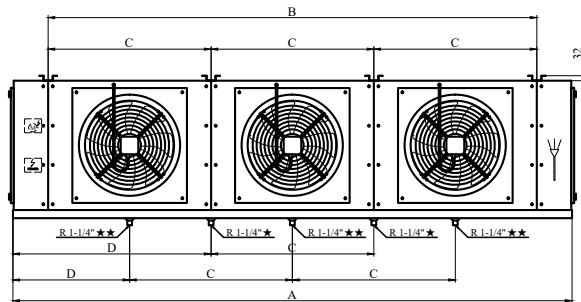

CEA
★5503
★★6303/8003

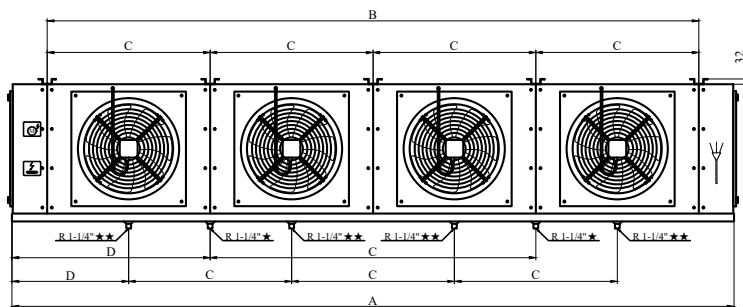

CEA
★5504
★★6304

型号	外形尺寸(mm)							
	A	B	C	D	E	F	G	H
CEA 5501...(4 rows)	1500	1030			525	635	260	870
CEA 5501...(6 rows)	1500	1030			525	635	260	870
CEA 5501...(8 rows)	1500	1030			595	705	260	870
CEA 5502...(4 rows)	2530	2060	1030		525	635	380	870
CEA 5502...(6 rows)	2530	2060	1030		525	635	380	870
CEA 5502...(8 rows)	2530	2060	1030		595	705	380	870
CEA 5503...(4 rows)	3560	3090	1030	750	525	635	460	870
CEA 5503...(6 rows)	3560	3090	1030	750	525	635	460	870
CEA 5503...(8 rows)	3560	3090	1030	750	595	705	460	870
CEA 5504...(4 rows)	4590	4120	1030	750	525	635	500	870
CEA 5504...(6 rows)	4590	4120	1030	750	525	635	500	870
CEA 5504...(8 rows)	4590	4120	1030	750	595	705	500	870
CEA 6301...(4 rows)	1700	1230			555	665	310	1010
CEA 6301...(6 rows)	1700	1230			555	665	310	1010
CEA 6301...(8 rows)	1700	1230			625	735	310	1010
CEA 6301...(10 rows)	1700	1230			695	805	310	1010
CEA 6302...(4 rows)	2930	2460	1230		555	665	440	1010
CEA 6302...(6 rows)	2930	2460	1230		555	665	440	1010
CEA 6302...(8 rows)	2930	2460	1230		625	735	440	1010
CEA 6302...(10 rows)	2930	2460	1230		695	805	440	1010
CEA 6303...(4 rows)	4160	3690	1230	850	555	665	530	1010
CEA 6303...(6 rows)	4160	3690	1230	850	555	665	530	1010
CEA 6303...(8 rows)	4160	3690	1230	850	625	735	530	1010
CEA 6303...(10 rows)	4160	3690	1230	850	695	805	530	1010
CEA 6304...(4 rows)	5390	4920	1230	850	555	665	580	1010
CEA 6304...(6 rows)	5390	4920	1230	850	555	665	580	1010
CEA 6304...(8 rows)	5390	4920	1230	850	625	735	580	1010
CEA 6304...(10 rows)	5390	4920	1230	850	695	805	580	1010
CEA 8001...(4 rows)	1900	1430			620	730	390	1360
CEA 8001...(6 rows)	1900	1430			620	730	390	1360
CEA 8001...(8 rows)	1900	1430			690	800	390	1360
CEA 8001...(10 rows)	1900	1430			760	870	390	1360
CEA 8002...(4 rows)	3330	2860	1430		620	730	580	1360
CEA 8002...(6 rows)	3330	2860	1430		620	730	580	1360
CEA 8002...(8 rows)	3330	2860	1430		690	800	580	1360
CEA 8002...(10 rows)	3330	2860	1430		760	870	580	1360
CEA 8003...(4 rows)	4760	4290	1430	950	620	730	700	1360
CEA 8003...(6 rows)	4760	4290	1430	950	620	730	700	1360
CEA 8003...(8 rows)	4760	4290	1430	950	690	800	700	1360
CEA 8003...(10 rows)	4760	4290	1430	950	760	870	700	1360

换热器宽度受其列数影响。列数可在之后的表格中查找。

片距 4 mm，带电加热。库温 $\geq 0^{\circ}\text{C}$

型号	制冷量 R744 (kw)		面积 (m ²)	管容积 (dm ³)	列数	净重 (kg)	接口尺寸 (ømm)	
	te= -8°C	te= -25°C					进	出
	DTI=8K	DTI=7K						
CEA 2501 09 4D	1.68	1.26	8.5	0.8		12	12	12
CEA 2502 17 4D	3.08	2.25	17.1	1.5		21	12	12
CEA 2503 26 4D	4.99	3.72	25.6	2.3		30	12	16
CEA 2504 35 4D	6.29	4.61	34.2	3		38	12	16
CEA 2505 41 4D	7.25	5.21	42.8	3.8		47	12	16
CEA 2506 52 4D	9.51	6.97	51.3	4.6		56	12	16
CEA 3001 12 4D	2.55	1.87	11.4	1		15	12	12
CEA 3002 23 4D	5.21	3.83	22.8	2		25	12	16
CEA 3003 35 4D	7.14	5.12	34.2	3		36	12	16
CEA 3004 46 4D	9.98	7.24	45.6	4		47	12	16
CEA 3005 56 4D	12.74	9.28	57	5.1		58	12	16
CEA 3006 69 4D	14.52	10.45	68.4	6.1		68	12	19
CEA 3501 14 4D	3.26	2.37	14.2	1.3		18	12	12
CEA 3502 27 4D	6.78	4.96	28.5	2.5		33	12	16
CEA 3503 41 4D	10.31	7.57	42.7	3.8		47	12	16
CEA 3504 55 4D	14.49	10.81	57	5.1		62	12	19
CEA 3505 70 4D	17.37	12.78	71.3	6.3		76	12	19
CEA 3506 83 4D	20.9	15.39	85.6	7.6		91	16	19
CEA 4001 20 4D	5.53	4.07	20.4	1.8		24	12	16
CEA 4002 40 4D	11.04	8.16	39.9	3.5		42	12	16
CEA 4003 54 4D	14.49	10.57	53.2	4.7		57	12	19
CEA 4004 81 4D	21.92	16.15	79.9	7.1		80	16	22
CEA 4501 31 4D	9.11	6.75	30.4	2.7		31	12	16
CEA 4502 61 4D	18.34	13.6	60.8	5.4		57	12	19
CEA 4503 92 4D	26.86	19.7	91.3	8.1		82	16	22
CEA 4504 119 4D	36.8	27.31	121.7	10.8		107	16	28
CEA 5001 39 4D	11.85	8.73	38.6	3.4	4	52	12	16
CEA 5001 58 4D	13.71	9.97	57.9	5.1	6	61	12	19
CEA 5001 76 4D	16.55	12.43	77.2	6.8	8	62	12	19
CEA 5002 81 4D	24.45	18.04	79.9	7.1	4	95	16	22
CEA 5002 121 4D	29.98	22.15	119.8	10.6	6	115	16	28
CEA 5002 156 4D	31.7	23.28	159.7	14.2	8	125	16	28
CEA 5003 122 4D	36.18	26.44	122.3	10.9	4	140	16	28
CEA 5003 183 4D	46.9	35	183.5	16.3	6	169	16	28
CEA 5003 237 4D	50.9	38.04	242.2	21.5	8	191	16	35
CEA 5004 159 4D	50.2	37.29	162.4	14.4	4	162	16	35
CEA 5004 238 4D	60.91	45.04	243.6	21.6	6	208	22	35
CEA 5004 318 4D	64.51	47.41	324.8	28.8	8	252	22	35

型号	风机							电加热		
	直径 (\varnothing mm)	数量	电压 (V, 50Hz)	功率 (W)	电流 (A)	风量 (m ³ /h)	射程 (m)	内芯 (W)	接水盘 (W)	总功率 (W)
CEA 2501 09 4D	250	1	1~230	44	0.2	730	4	2×440	1×440	1320
CEA 2502 17 4D	250	2	1~230	88	0.4	1461	5	2×730	1×730	2190
CEA 2503 26 4D	250	3	1~230	132	0.6	2192	6	2×1030	1×1030	3090
CEA 2504 35 4D	250	4	1~230	176	0.8	2923	7	2×1310	1×1310	3930
CEA 2505 41 4D	250	5	1~230	220	1	3654	8	2×1600	1×1600	4800
CEA 2506 52 4D	250	6	1~230	264	1.2	4386	10	2×1890	1×1890	5670
CEA 3001 12 4D	300	1	1~230	72	0.3	1277	6	3×440	1×440	1760
CEA 3002 23 4D	300	2	1~230	144	0.6	2556	7	3×730	1×730	2920
CEA 3003 35 4D	300	3	1~230	216	1	3834	9	3×1030	1×1030	4120
CEA 3004 46 4D	300	4	1~230	288	1.3	5113	10	3×1310	1×1310	5240
CEA 3005 56 4D	300	5	1~230	360	1.6	6392	13	3×1600	1×1600	6400
CEA 3006 69 4D	300	6	1~230	432	1.9	7670	15	3×1890	1×1890	7560
CEA 3501 14 4D	350	1	1~230	130	0.6	1734	10	4×440	2×440	2640
CEA 3502 27 4D	350	2	1~230	260	1.2	3473	13	4×730	2×730	4380
CEA 3503 41 4D	350	3	1~230	390	1.7	5212	16	4×1030	2×1030	6180
CEA 3504 55 4D	350	4	1~230	520	2.3	6953	19	4×1310	2×1310	7860
CEA 3505 70 4D	350	5	1~230	650	2.9	8691	21	4×1600	2×1600	9600
CEA 3506 83 4D	350	6	1~230	780	3.5	10430	23	4×1890	2×1890	11340
CEA 4001 20 4D	400	1	1~230	160	0.7	3111	11	4×550	1×550	2750
CEA 4002 40 4D	400	2	1~230	320	1.5	6161	13	4×1030	1×1030	5150
CEA 4003 54 4D	400	3	1~230	480	2.2	8741	16	4×1310	1×1310	6550
CEA 4004 81 4D	400	4	1~230	640	2.9	12325	19	4×1890	1×1890	9450
CEA 4501 31 4D	450	1	3~400	460	1	5422	15	4×730	1×730	3650
CEA 4502 61 4D	450	2	3~400	920	1.9	10849	18	4×1310	1×1310	6550
CEA 4503 92 4D	450	3	3~400	1380	2.9	16269	21	4×1890	1×1890	9450
CEA 4504 119 4D	450	4	3~400	1840	3.8	21703	23	4×2470	1×2470	12350
CEA 5001 39 4D	500	1	3~400	820	1.6	7400	20	6×730	1×730	5110
CEA 5001 58 4D	500	1	3~400	820	1.6	6610	17	7×730	2×730	6570
CEA 5001 76 4D	500	1	3~400	820	1.6	6027	14	8×730	2×730	7300
CEA 5002 81 4D	500	2	3~400	1640	3.2	15002	24	6×1400	1×1400	9800
CEA 5002 121 4D	500	2	3~400	1640	3.2	13443	20	7×1400	2×1400	12600
CEA 5002 156 4D	500	2	3~400	1640	3.2	12284	16	8×1400	2×1400	14000
CEA 5003 122 4D	500	3	3~400	2460	4.8	22673	29	6×2050	1×2050	14350
CEA 5003 183 4D	500	3	3~400	2460	4.8	20375	24	7×2050	2×2050	18450
CEA 5003 237 4D	500	3	3~400	2460	4.8	18543	19	8×2050	2×2050	20500
CEA 5004 159 4D	500	4	3~400	3280	6.4	30197	34	6×3390	1×3390	23730
CEA 5004 238 4D	500	4	3~400	3280	6.4	27102	29	7×3390	2×3390	30510
CEA 5004 318 4D	500	4	3~400	3280	6.4	24797	24	8×3390	2×3390	33900

片距 6 mm，带电加热。库温 $\geq -18^{\circ}\text{C}$

型号	制冷量 R744 (kw)		面积 (m ²)	管容积 (dm ³)	列数	净重 (kg)	接口尺寸 (ømm)	
	te= -8°C	te= -25°C					进	出
	DTI=8K	DTI=7K						
CEA 2501 06 6D	1.47	1.08	5.8	0.8		12	12	12
CEA 2502 11 6D	2.78	2.01	11.7	1.5		20	12	12
CEA 2503 17 6D	4.42	3.25	17.5	2.3		29	12	16
CEA 2504 23 6D	5.66	4.11	23.4	3		37	12	16
CEA 2505 29 6D	6.62	4.74	29.2	3.8		45	12	16
CEA 2506 35 6D	8.54	6.21	35.1	4.6		54	12	16
CEA 3001 08 6D	2.21	1.61	7.8	1		14	12	12
CEA 3002 15 6D	4.5	3.29	15.6	2		25	12	16
CEA 3003 23 6D	6.32	4.55	23.4	3		35	12	16
CEA 3004 31 6D	8.74	6.35	31.2	4		45	12	16
CEA 3005 38 6D	11.09	8.08	39	5.1		55	12	16
CEA 3006 46 6D	12.82	9.25	46.8	6.1		66	12	19
CEA 3501 10 6D	2.97	2.16	9.7	1.3		18	12	12
CEA 3502 19 6D	6.13	4.49	19.4	2.5		32	12	16
CEA 3503 28 6D	9.3	6.82	29.2	3.8		46	12	16
CEA 3504 38 6D	12.89	9.58	38.9	5.1		60	12	19
CEA 3505 48 6D	15.83	11.5	48.7	6.3		74	12	19
CEA 3506 57 6D	18.8	13.84	58.4	7.6		88	16	19
CEA 4001 13 6D	4.74	3.48	13.9	1.8		23	12	16
CEA 4002 27 6D	9.45	6.95	27.3	3.5		41	12	16
CEA 4003 36 6D	12.67	9.24	36.4	4.7		55	12	19
CEA 4004 54 6D	18.85	13.83	54.6	7.1		78	16	22
CEA 4501 20 6D	7.68	5.66	20.7	2.7		30	12	16
CEA 4502 41 6D	15.44	11.38	41.5	5.4		54	12	19
CEA 4503 61 6D	23	16.85	62.3	8.1		79	16	22
CEA 4504 82 6D	30.95	22.82	83.1	10.8		103	16	28
CEA 5001 26 6D	10.12	7.43	26.4	3.4	4	51	12	16
CEA 5001 39 6D	12.39	9	39.5	5.1	6	59	12	19
CEA 5001 52 6D	14.87	11.09	52.7	6.8	8	59	12	19
CEA 5002 54 6D	20.84	15.32	54.6	7.1	4	93	16	22
CEA 5002 81 6D	26.66	19.63	81.8	10.6	6	110	16	28
CEA 5002 108 6D	29.06	21.31	109.1	14.2	8	120	16	28
CEA 5003 82 6D	31.17	22.78	83.6	10.9	4	135	16	28
CEA 5003 122 6D	41.22	30.56	125.3	16.3	6	162	16	28
CEA 5003 163 6D	45.98	34.16	165.5	21.5	8	182	16	35
CEA 5004 109 6D	41.63	30.62	110.9	14.4	4	156	16	35
CEA 5004 164 6D	53.37	39.32	166.4	21.6	6	199	22	35
CEA 5004 219 6D	59.09	43.35	221.8	28.8	8	240	22	35

型号	风机							电加热		
	直径 (\varnothing mm)	数量	电压 (V, 50Hz)	功率 (W)	电流 (A)	风量 (m ³ /h)	射程 (m)	内芯 (W)	接水盘 (W)	总功率 (W)
CEA 2501 06 6D	250	1	1~230	44	0.2	793	4	2×440	1×440	1320
CEA 2502 11 6D	250	2	1~230	88	0.4	1587	5	2×730	1×730	2190
CEA 2503 17 6D	250	3	1~230	132	0.6	2382	6	2×1030	1×1030	3090
CEA 2504 23 6D	250	4	1~230	176	0.8	3175	7	2×1310	1×1310	3930
CEA 2505 29 6D	250	5	1~230	220	1	3969	8	2×1600	1×1600	4800
CEA 2506 35 6D	250	6	1~230	264	1.2	4764	10	2×1890	1×1890	5670
CEA 3001 08 6D	300	1	1~230	72	0.3	1341	6	3×440	1×440	1760
CEA 3002 15 6D	300	2	1~230	144	0.6	2683	7	3×730	1×730	2920
CEA 3003 23 6D	300	3	1~230	216	1	4025	9	3×1030	1×1030	4120
CEA 3004 31 6D	300	4	1~230	288	1.3	5367	11	3×1310	1×1310	5240
CEA 3005 38 6D	300	5	1~230	360	1.6	6710	13	3×1600	1×1600	6400
CEA 3006 46 6D	300	6	1~230	432	1.9	8051	15	3×1890	1×1890	7560
CEA 3501 10 6D	350	1	1~230	130	0.6	1894	10	4×440	2×440	2640
CEA 3502 19 6D	350	2	1~230	260	1.2	3793	14	4×730	2×730	4380
CEA 3503 28 6D	350	3	1~230	390	1.7	5693	16	4×1030	2×1030	6180
CEA 3504 38 6D	350	4	1~230	520	2.3	7595	20	4×1310	2×1310	7860
CEA 3505 48 6D	350	5	1~230	650	2.9	9492	22	4×1600	2×1600	9600
CEA 3506 57 6D	350	6	1~230	780	3.5	11392	24	4×1890	2×1890	11340
CEA 4001 13 6D	400	1	1~230	160	0.7	3271	11	4×550	1×550	2750
CEA 4002 27 6D	400	2	1~230	320	1.5	6491	14	4×1030	1×1030	5150
CEA 4003 36 6D	400	3	1~230	480	2.2	9294	16	4×1310	1×1310	6550
CEA 4004 54 6D	400	4	1~230	640	2.9	12983	19	4×1890	1×1890	9450
CEA 4501 20 6D	450	1	3~400	460	1	5656	15	4×730	1×730	3650
CEA 4502 41 6D	450	2	3~400	920	1.9	11317	18	4×1310	1×1310	6550
CEA 4503 61 6D	450	3	3~400	1380	2.9	16969	22	4×1890	1×1890	9450
CEA 4504 82 6D	450	4	3~400	1840	3.8	22638	24	4×2470	1×2470	12350
CEA 5001 26 6D	500	1	3~400	820	1.6	7764	24	6×730	1×730	5110
CEA 5001 39 6D	500	1	3~400	820	1.6	7031	21	7×730	2×730	6570
CEA 5001 52 6D	500	1	3~400	770	1.7	6304	18	8×730	2×730	7300
CEA 5002 54 6D	500	2	3~400	1640	3.2	15703	24	6×1400	1×1400	9800
CEA 5002 81 6D	500	2	3~400	1640	3.2	14278	20	7×1400	2×1400	12600
CEA 5002 108 6D	500	2	3~400	1540	3.3	12832	16	8×1400	2×1400	14000
CEA 5003 82 6D	500	3	3~400	2460	4.8	23711	29	6×2050	1×2050	14350
CEA 5003 122 6D	500	3	3~400	2460	4.8	21621	24	7×2050	2×2050	18450
CEA 5003 163 6D	500	3	3~400	2310	5	19362	19	8×2050	2×2050	20500
CEA 5004 109 6D	500	4	3~400	3080	6.6	30519	34	6×3390	1×3390	23730
CEA 5004 164 6D	500	4	3~400	3080	6.6	28029	29	7×3390	2×3390	30510
CEA 5004 219 6D	500	4	3~400	3080	6.6	25885	24	8×3390	2×3390	33900

片距 9 mm，带电加热。库温 $\geq -35^{\circ}\text{C}$

型号	制冷量 R744 (kw)		面积 (m ²)	管容积 (dm ³)	列数	净重 (kg)	接口尺寸 (ømm)	
	te= -8°C	te= -25°C					进	出
	DTI=8K	DTI=7K						
CEA 2501 04 9D	1.21	0.88	4	0.8		11	12	12
CEA 2502 08 9D	2.37	1.71	8.1	1.5		19	12	12
CEA 2503 12 9D	3.68	2.68	12.1	2.3		27	12	16
CEA 2504 16 9D	4.79	3.47	16.1	3		36	12	16
CEA 2505 20 9D	5.72	4.09	20.2	3.8		44	12	16
CEA 2506 24 9D	7.22	5.23	24.2	4.6		51	12	16
CEA 3001 06 9D	1.84	1.34	5.4	1		14	12	12
CEA 3002 10 9D	3.72	2.71	10.7	2		24	12	16
CEA 3003 16 9D	5.36	3.87	16.1	3		33	12	16
CEA 3004 21 9D	7.33	5.32	21.5	4		43	12	16
CEA 3005 27 9D	9.25	6.73	26.9	5.1		53	12	16
CEA 3006 31 9D	10.84	7.84	32.3	6.1		63	12	19
CEA 3501 07 9D	2.59	1.88	6.7	1.3		17	12	12
CEA 3502 13 9D	5.31	3.88	13.4	2.5		31	12	16
CEA 3503 20 9D	8.03	5.88	20.2	3.8		44	12	16
CEA 3504 27 9D	10.98	8.11	26.9	5.1		57	12	19
CEA 3505 34 9D	13.47	9.89	33.6	6.3		70	12	19
CEA 3506 40 9D	16.2	11.89	40.4	7.6		84	16	19
CEA 4001 09 9D	3.9	2.85	9.6	1.8		22	12	16
CEA 4002 18 9D	7.75	5.68	18.8	3.5		39	12	16
CEA 4003 24 9D	10.59	7.72	25.1	4.7		53	12	19
CEA 4004 36 9D	15.53	11.36	37.7	7.1		74	16	22
CEA 4501 14 9D	6.24	4.56	14.3	2.7		28	12	16
CEA 4502 28 9D	12.52	9.15	28.7	5.4		51	12	19
CEA 4503 41 9D	18.91	13.82	43.1	8.1		74	16	22
CEA 4504 57 9D	25.08	18.35	57.4	10.8		97	16	28
CEA 5001 17 9D	8.3	6.07	18.2	3.4	4	49	12	16
CEA 5001 26 9D	10.71	7.79	27.3	5.1	6	57	12	19
CEA 5001 36 9D	13.14	9.72	36.4	6.8	8	56	12	19
CEA 5002 36 9D	17.05	12.48	37.7	7.1	4	89	16	22
CEA 5002 54 9D	22.66	16.63	56.5	10.6	6	105	16	28
CEA 5002 75 9D	26.12	19.11	75.4	14.2	8	112	16	28
CEA 5003 54 9D	25.75	18.77	57.7	10.9	4	129	16	28
CEA 5003 82 9D	34.65	25.5	86.6	16.3	6	154	16	28
CEA 5003 114 9D	40.78	30.12	114.3	21.5	8	170	16	35
CEA 5004 76 9D	34.37	25.17	76.6	14.4	4	149	16	35
CEA 5004 114 9D	45.96	33.73	114.9	21.6	6	188	22	35
CEA 5004 152 9D	53.06	38.85	153.2	28.8	8	225	22	35

型号	风机							电加热		
	直径 (\varnothing mm)	数量	电压 (V, 50Hz)	功率 (W)	电流 (A)	风量 (m ³ /h)	射程 (m)	内芯 (W)	接水盘 (W)	总功率 (W)
CEA 2501 04 9D	250	1	1~230	44	0.2	834	4	2×440	1×440	1320
CEA 2502 08 9D	250	2	1~230	88	0.4	1668	5	2×730	1×730	2190
CEA 2503 12 9D	250	3	1~230	132	0.6	2503	6	2×1030	1×1030	3090
CEA 2504 16 9D	250	4	1~230	176	0.8	3337	7	2×1310	1×1310	3930
CEA 2505 20 9D	250	5	1~230	220	1	4171	9	2×1600	1×1600	4800
CEA 2506 24 9D	250	6	1~230	264	1.2	5006	10	2×1890	1×1890	5670
CEA 3001 06 9D	300	1	1~230	72	0.3	1404	6	3×440	1×440	1760
CEA 3002 10 9D	300	2	1~230	144	0.6	2810	7	3×730	1×730	2920
CEA 3003 16 9D	300	3	1~230	216	1	4214	9	3×1030	1×1030	4120
CEA 3004 21 9D	300	4	1~230	288	1.3	5620	11	3×1310	1×1310	5240
CEA 3005 27 9D	300	5	1~230	360	1.6	7026	13	3×1600	1×1600	6400
CEA 3006 31 9D	300	6	1~230	432	1.9	8430	15	3×1890	1×1890	7560
CEA 3501 07 9D	350	1	1~230	130	0.6	2059	11	4×440	2×440	2640
CEA 3502 13 9D	350	2	1~230	260	1.2	4124	14	4×730	2×730	4380
CEA 3503 20 9D	350	3	1~230	390	1.7	6189	17	4×1030	2×1030	6180
CEA 3504 27 9D	350	4	1~230	520	2.3	8257	20	4×1310	2×1310	7860
CEA 3505 34 9D	350	5	1~230	650	2.9	10319	22	4×1600	2×1600	9600
CEA 3506 40 9D	350	6	1~230	780	3.5	12384	24	4×1890	2×1890	11340
CEA 4001 09 9D	400	1	1~230	160	0.7	3418	11	4×550	1×550	2750
CEA 4002 18 9D	400	2	1~230	320	1.5	6788	14	4×1030	1×1030	5150
CEA 4003 24 9D	400	3	1~230	480	2.2	9780	16	4×1310	1×1310	6550
CEA 4004 36 9D	400	4	1~230	640	2.9	13578	20	4×1890	1×1890	9450
CEA 4501 14 9D	450	1	3~400	460	1	5878	15	4×730	1×730	3650
CEA 4502 28 9D	450	2	3~400	920	1.9	11759	18	4×1310	1×1310	6550
CEA 4503 41 9D	450	3	3~400	1380	2.9	17632	22	4×1890	1×1890	9450
CEA 4504 57 9D	450	4	3~400	1840	3.8	23521	24	4×2470	1×2470	12350
CEA 5001 17 9D	500	1	3~400	820	1.6	8094	26	6×730	1×730	5110
CEA 5001 26 9D	500	1	3~400	820	1.6	7437	23	7×730	2×730	6570
CEA 5001 36 9D	500	1	3~400	820	1.6	6892	20	8×730	2×730	7300
CEA 5002 36 9D	500	2	3~400	1640	3.2	16344	24	6×1400	1×1400	9800
CEA 5002 54 9D	500	2	3~400	1640	3.2	15075	20	7×1400	2×1400	12600
CEA 5002 75 9D	500	2	3~400	1640	3.2	13995	16	8×1400	2×1400	14000
CEA 5003 54 9D	500	3	3~400	2460	4.8	24638	29	6×2050	1×2050	14350
CEA 5003 82 9D	500	3	3~400	2460	4.8	22793	24	7×2050	2×2050	18450
CEA 5003 114 9D	500	3	3~400	2460	4.8	21102	19	8×2050	2×2050	20500
CEA 5004 76 9D	500	4	3~400	3280	6.4	32828	34	6×3390	1×3390	23730
CEA 5004 114 9D	500	4	3~400	3280	6.4	30332	29	7×3390	2×3390	30510
CEA 5004 152 9D	500	4	3~400	3280	6.4	28200	24	8×3390	2×3390	33900

片距 4 mm，带电加热。库温 $\geq 0^{\circ}\text{C}$

型号	制冷量 R744 (kw)		面积 (m ²)	管容积 (dm ³)	列数	净重 (kg)	接口尺寸 (ømm)	
	te= -8°C	te= -25°C					进	出
	DTI=8K	DTI=7K						
CEA 5501 51 4D	13.55	9.8	52.1	4.6	4	67	12	19
CEA 5501 76 4D	17.3	12.65	78.1	6.9	6	83	12	19
CEA 5501 102 4D	19.44	14.4	104.1	9.2	8	134	16	19
CEA 5502 105 4D	29.11	21.38	107.1	9.5	4	162	16	22
CEA 5502 157 4D	34.78	25.3	160.6	14.3	6	201	16	28
CEA 5502 210 4D	40.7	30.46	214.1	19	8	244	16	28
CEA 5503 159 4D	41.04	29.57	162.1	14.4	4	265	16	28
CEA 5503 238 4D	54.97	40.53	243.1	21.6	6	323	16	35
CEA 5503 317 4D	59.27	43.79	324.1	28.8	8	97	22	35
CEA 5504 212 4D	58.84	43.24	217.1	19.3	4	117	16	35
CEA 5504 319 4D	70.44	51.26	325.6	28.9	6	189	22	35
CEA 5504 425 4D	73.3	53.11	434.1	38.5	8	231	22	35
CEA 6301 73 4D	20.54	15.27	74.2	6.6	4	144	16	19
CEA 6301 109 4D	26.28	19.47	111.2	9.9	6	168	16	22
CEA 6301 145 4D	29.17	21.64	148.3	13.2	8	195	16	22
CEA 6301 181 4D	27.96	21.07	181.4	27.5	10	226	16	28
CEA 6302 149 4D	41.48	30.27	151.8	13.5	4	262	16	35
CEA 6302 223 4D	53.45	39.61	227.7	20.2	6	312	22	35
CEA 6302 297 4D	59.32	44.05	303.6	26.9	8	365	22	35
CEA 6302 371 4D	55.57	41.08	371.2	56.2	10	422	22	42
CEA 6303 224 4D	64.09	47.21	229.4	20.4	4	382	22	42
CEA 6303 337 4D	78.1	57.2	344.1	30.5	6	454	22	42
CEA 6303 449 4D	83.05	60.41	458.8	40.7	8	533	22	42
CEA 6303 561 4D	87.32	65.88	561.1	85	10	617	2×22	2×35
CEA 6304 300 4D	83.78	61.18	307	27.2	4	498	16	28
CEA 6304 451 4D	96.55	69.36	460.5	40.9	6	595	16	28
CEA 6304 601 4D	119.66	88.87	614.1	54.5	8	701	16	28
CEA 6304 751 4D	119.96	89.29	750.9	113.7	10	810	22	35
CEA 8001 118 4D	33.5	24.62	120.1	10.7	4	205	22	42
CEA 8001 176 4D	39.54	28.65	180.2	16	6	243	22	42
CEA 8001 235 4D	45.75	33.94	240.3	21.3	8	291	22	42
CEA 8001 294 4D	41.56	31.34	293.9	44.5	10	333	22	54
CEA 8002 240 4D	64.94	47.09	245.1	21.7	4	375	2×22	2×35
CEA 8002 360 4D	82.85	60.56	367.7	32.6	6	454	16	22
CEA 8002 480 4D	93.07	69.11	490.2	43.5	8	547	16	35
CEA 8002 600 4D	89.04	67.05	599.5	90.8	10	627	2×16	2×28
CEA 8003 362 4D	102.72	75.56	370.1	32.8	4	548	2×22	2×35
CEA 8003 543 4D	121.61	88.24	555.1	49.3	6	664	16	28
CEA 8003 724 4D	143.77	107.77	740.1	65.7	8	799	22	42
CEA 8003 905 4D	139.69	105.42	905.1	137.1	10	916	2×22	2×35

型号	风机							电加热		
	直径 (\varnothing mm)	数量	电压 (V, 50Hz)	功率 (W)	电流 (A)	风量 (m ³ /h)	射程 (m)	内芯 (W)	接水盘 (W)	总功率 (W)
CEA 5501 51 4D	550	1	3~400	770	1.7	7834	16	4×1280	1×1280	6400
CEA 5501 76 4D	550	1	3~400	770	1.7	7347	15	6×1280	2×1280	10240
CEA 5501 102 4D	550	1	3~400	770	1.7	6848	14	8×1280	2×1280	12800
CEA 5502 105 4D	550	2	3~400	1540	3.3	15762	19	4×2320	1×2320	11600
CEA 5502 157 4D	550	2	3~400	1540	3.3	14844	18	6×2320	2×2320	18560
CEA 5502 210 4D	550	2	3~400	1540	3.3	13862	17	8×2320	2×2320	23200
CEA 5503 159 4D	550	3	3~400	2310	5	23682	22	4×3200	1×3200	16000
CEA 5503 238 4D	550	3	3~400	2310	5	22336	21	6×3200	2×3200	25600
CEA 5503 317 4D	550	3	3~400	2310	5	20871	20	8×3200	2×3200	32000
CEA 5504 212 4D	550	4	3~400	3080	6.6	31611	28	4×4260	1×4260	21300
CEA 5504 319 4D	550	4	3~400	3080	6.6	29823	26	6×4260	2×4260	34080
CEA 5504 425 4D	550	4	3~400	3080	6.6	27879	24	8×4260	2×4260	42600
CEA 6301 73 4D	630	1	3~400	1100	2.2	11682	19	5×1510	1×1510	9060
CEA 6301 109 4D	630	1	3~400	1100	2.2	11098	18	7×1510	2×1510	13590
CEA 6301 145 4D	630	1	3~400	1100	2.2	10484	17	9×1510	2×1510	16610
CEA 6301 181 4D	630	1	3~400	1100	2.2	9848	16	12×1510	2×1510	21140
CEA 6302 149 4D	630	2	3~400	2200	4.4	23475	22	5×2740	1×2740	16440
CEA 6302 223 4D	630	2	3~400	2200	4.4	22339	21	7×2740	2×2740	24660
CEA 6302 297 4D	630	2	3~400	2200	4.4	21147	20	9×2740	2×2740	30140
CEA 6302 371 4D	630	2	3~400	2200	4.4	19873	19	12×2740	2×2740	38360
CEA 6303 224 4D	630	3	3~400	3300	6.6	35279	28	5×3800	1×3800	22800
CEA 6303 337 4D	630	3	3~400	3300	6.6	33580	26	7×3800	2×3800	34200
CEA 6303 449 4D	630	3	3~400	3300	6.6	31793	24	9×3800	2×3800	41800
CEA 6303 561 4D	630	3	3~400	3300	6.6	29884	22	12×3800	2×3800	53200
CEA 6304 300 4D	630	4	3~400	4400	8.8	47056	33	5×5060	1×5060	30360
CEA 6304 451 4D	630	4	3~400	4400	8.8	44773	31	7×5060	2×5060	45540
CEA 6304 601 4D	630	4	3~400	4400	8.8	42390	29	9×5060	2×5060	55660
CEA 6304 751 4D	630	4	3~400	4400	8.8	39893	27	12×5060	2×5060	70840
CEA 8001 118 4D	800	1	3~400	1600	3.5	18865	25	7×1700	1×1700	13600
CEA 8001 176 4D	800	1	3~400	1600	3.5	17867	23	10×1700	2×1700	20400
CEA 8001 235 4D	800	1	3~400	1600	3.5	16606	21	16×1700	2×1700	30600
CEA 8001 294 4D	800	1	3~400	1600	3.5	15353	19	16×1700	2×1700	30600
CEA 8002 240 4D	800	2	3~400	3200	7	37904	29	7×2810	1×2810	22480
CEA 8002 360 4D	800	2	3~400	3200	7	35940	27	10×2810	2×2810	33720
CEA 8002 480 4D	800	2	3~400	3200	7	33541	25	16×2810	2×2810	50580
CEA 8002 600 4D	800	2	3~400	3200	7	31007	23	16×2810	2×2810	50580
CEA 8003 362 4D	800	3	3~400	4800	10.5	56974	34	7×4420	1×4420	35360
CEA 8003 543 4D	800	3	3~400	4800	10.5	53941	32	10×4420	2×4420	53040
CEA 8003 724 4D	800	3	3~400	4800	10.5	50373	30	16×4420	2×4420	79560
CEA 8003 905 4D	800	3	3~400	4800	10.5	46651	28	16×4420	2×4420	79560

片距 6 mm，带电加热。库温 $\geq -18^{\circ}\text{C}$

型号	制冷量 R744 (kw)		面积 (m ²)	管容积 (dm ³)	列数	净重 (kg)	接口尺寸 (ømm)	
	te= -8°C	te= -25°C					进	出
	DTI=8K	DTI=7K						
CEA 5501 35 6D	11.65	8.43	35.6	4.6	4	64	12	19
CEA 5501 53 6D	15.33	11.16	53.3	6.9	6	79	12	19
CEA 5501 70 6D	17.84	13.14	71.1	9.2	8	128	16	19
CEA 5502 72 6D	24.51	17.93	73.1	9.5	4	154	16	22
CEA 5502 108 6D	30.9	22.44	109.7	14.3	6	192	16	28
CEA 5502 144 6D	36.96	27.37	146.3	19	8	232	16	28
CEA 5503 109 6D	35.45	25.59	110.7	14.4	4	253	16	28
CEA 5503 164 6D	48.09	35.25	166.1	21.6	6	307	16	35
CEA 5503 218 6D	54.53	40.01	221.4	28.8	8	93	22	35
CEA 5504 146 6D	49.52	36.22	148.3	19.3	4	111	16	35
CEA 5504 219 6D	62.5	45.41	222.4	28.9	6	180	22	35
CEA 5504 292 6D	68.46	49.45	296.6	38.5	8	220	22	35
CEA 6301 50 6D	17.07	12.53	50.7	6.6	4	141	16	19
CEA 6301 75 6D	22.86	16.79	76	9.9	6	164	16	22
CEA 6301 100 6D	26.43	19.49	101.3	13.2	8	190	16	22
CEA 6301 125 6D	25.08	18.7	124.7	27.5	10	219	16	28
CEA 6302 102 6D	35.24	25.64	103.7	13.5	4	256	16	35
CEA 6302 153 6D	46.45	34.14	155.5	20.2	6	303	22	35
CEA 6302 204 6D	53.76	39.66	207.4	26.9	8	354	22	35
CEA 6302 255 6D	48.62	35.96	255.3	56.2	10	408	22	42
CEA 6303 154 6D	53.7	39.26	156.7	20.4	4	373	22	42
CEA 6303 232 6D	68.94	50.32	235.1	30.5	6	441	22	42
CEA 6303 309 6D	76.66	55.67	313.4	40.7	8	516	22	42
CEA 6303 386 6D	78.92	59.87	385.9	85	10	596	2×22	2×35
CEA 6304 207 6D	71.12	51.76	209.7	27.2	4	487	16	28
CEA 6304 310 6D	86.89	62.5	314.6	40.9	6	577	16	28
CEA 6304 413 6D	108.41	80	419.5	54.5	8	678	16	28
CEA 6304 517 6D	109.39	81.8	516.5	113.7	10	781	22	35
CEA 8001 81 6D	28.36	20.75	82.1	10.7	4	201	22	42
CEA 8001 121 6D	35.29	25.58	123.1	16	6	236	22	42
CEA 8001 162 6D	42.08	30.96	164.1	21.3	8	282	22	42
CEA 8001 202 6D	36.1	27.42	202.1	44.5	10	322	22	54
CEA 8002 165 6D	55.93	40.55	167.4	21.7	4	366	2×22	2×35
CEA 8002 247 6D	73.3	53.5	251.1	32.6	6	441	16	22
CEA 8002 330 6D	85.55	62.9	334.9	43.5	8	529	16	35
CEA 8002 412 6D	80.7	59.98	412.3	90.8	10	604	2×16	2×28
CEA 8003 249 6D	86.85	63.56	252.8	32.8	4	534	2×22	2×35
CEA 8003 374 6D	108.31	78.67	379.2	49.3	6	643	16	28
CEA 8003 498 6D	130.94	96.81	505.6	65.7	8	771	22	42
CEA 8003 623 6D	128.47	97.28	622.5	137.1	10	881	2×22	2×35

型号	风机							电加热		
	直径 (\varnothing mm)	数量	电压 (V, 50Hz)	功率 (W)	电流 (A)	风量 (m ³ /h)	射程 (m)	内芯 (W)	接水盘 (W)	总功率 (W)
CEA 5501 35 6D	550	1	3 ~ 400	770	1.7	8042	17	4 × 1280	1 × 1280	6400
CEA 5501 53 6D	550	1	3 ~ 400	770	1.7	7630	16	6 × 1280	2 × 1280	10240
CEA 5501 70 6D	550	1	3 ~ 400	770	1.7	7223	15	8 × 1280	2 × 1280	12800
CEA 5502 72 6D	550	2	3 ~ 400	1540	3.3	16170	20	4 × 2320	1 × 2320	11600
CEA 5502 108 6D	550	2	3 ~ 400	1540	3.3	15360	19	6 × 2320	2 × 2320	18560
CEA 5502 144 6D	550	2	3 ~ 400	1540	3.3	14605	18	8 × 2320	2 × 2320	23200
CEA 5503 109 6D	550	3	3 ~ 400	2310	5	24291	23	4 × 3200	1 × 3200	16000
CEA 5503 164 6D	550	3	3 ~ 400	2310	5	23091	22	6 × 3200	2 × 3200	25600
CEA 5503 218 6D	550	3	3 ~ 400	2310	5	21980	21	8 × 3200	2 × 3200	32000
CEA 5504 146 6D	550	4	3 ~ 400	3080	6.6	32420	27	4 × 4260	1 × 4260	21300
CEA 5504 219 6D	550	4	3 ~ 400	3080	6.6	30816	26	6 × 4260	2 × 4260	34080
CEA 5504 292 6D	550	4	3 ~ 400	3080	6.6	29354	25	8 × 4260	2 × 4260	42600
CEA 6301 50 6D	630	1	3 ~ 400	1100	2.2	11978	20	5 × 1510	1 × 1510	9060
CEA 6301 75 6D	630	1	3 ~ 400	1100	2.2	11491	19	7 × 1510	2 × 1510	13590
CEA 6301 100 6D	630	1	3 ~ 400	1100	2.2	10943	18	9 × 1510	2 × 1510	16610
CEA 6301 125 6D	630	1	3 ~ 400	1100	2.2	10319	17	12 × 1510	2 × 1510	21140
CEA 6302 102 6D	630	2	3 ~ 400	2200	4.4	24044	23	5 × 2740	1 × 2740	16440
CEA 6302 153 6D	630	2	3 ~ 400	2200	4.4	23101	22	7 × 2740	2 × 2740	24660
CEA 6302 204 6D	630	2	3 ~ 400	2200	4.4	22053	21	9 × 2740	2 × 2740	30140
CEA 6302 255 6D	630	2	3 ~ 400	2200	4.4	20822	20	12 × 2740	2 × 2740	38360
CEA 6303 154 6D	630	3	3 ~ 400	3300	6.6	36112	27	5 × 3800	1 × 3800	22800
CEA 6303 232 6D	630	3	3 ~ 400	3300	6.6	34706	26	7 × 3800	2 × 3800	34200
CEA 6303 309 6D	630	3	3 ~ 400	3300	6.6	33133	25	9 × 3800	2 × 3800	41800
CEA 6303 386 6D	630	3	3 ~ 400	3300	6.6	31295	24	12 × 3800	2 × 3800	53200
CEA 6304 207 6D	630	4	3 ~ 400	4400	8.8	48157	34	5 × 5060	1 × 5060	30360
CEA 6304 310 6D	630	4	3 ~ 400	4400	8.8	46274	32	7 × 5060	2 × 5060	45540
CEA 6304 413 6D	630	4	3 ~ 400	4400	8.8	44201	30	9 × 5060	2 × 5060	55660
CEA 6304 517 6D	630	4	3 ~ 400	4400	8.8	41769	28	12 × 5060	2 × 5060	70840
CEA 8001 81 6D	800	1	3 ~ 400	1600	3.5	19462	25	7 × 1700	1 × 1700	13600
CEA 8001 121 6D	800	1	3 ~ 400	1600	3.5	18472	24	10 × 1700	2 × 1700	20400
CEA 8001 162 6D	800	1	3 ~ 400	1600	3.5	17550	23	16 × 1700	2 × 1700	30600
CEA 8001 202 6D	800	1	3 ~ 400	1600	3.5	16389	22	16 × 1700	2 × 1700	30600
CEA 8002 165 6D	800	2	3 ~ 400	3200	7	39071	29	7 × 2810	1 × 2810	22480
CEA 8002 247 6D	800	2	3 ~ 400	3200	7	37129	28	10 × 2810	2 × 2810	33720
CEA 8002 330 6D	800	2	3 ~ 400	3200	7	35407	27	16 × 2810	2 × 2810	50580
CEA 8002 412 6D	800	2	3 ~ 400	3200	7	33034	26	16 × 2810	2 × 2810	50580
CEA 8003 249 6D	800	3	3 ~ 400	4800	10.5	58702	34	7 × 4420	1 × 4420	35360
CEA 8003 374 6D	800	3	3 ~ 400	4800	10.5	55725	33	10 × 4420	2 × 4420	53040
CEA 8003 498 6D	800	3	3 ~ 400	4800	10.5	53203	32	16 × 4420	2 × 4420	79560
CEA 8003 623 6D	800	3	3 ~ 400	4800	10.5	49668	31	16 × 4420	2 × 4420	79560

片距 9 mm，带电加热。库温 $\geq -35^{\circ}\text{C}$

型号	制冷量 R744 (kw)		面积 (m ²)	管容积 (dm ³)	列数	净重 (kg)	接口尺寸 (ømm)	
	te= -8°C	te= -25°C					进	出
	DTI=8K	DTI=7K						
CEA 5501 24 9D	9.6	6.95	24.6	4.6	4	60	12	19
CEA 5501 37 9D	12.96	9.42	36.8	6.9	6	74	12	19
CEA 5501 49 9D	15.56	11.36	49.1	9.2	8	120	16	19
CEA 5502 50 9D	19.83	14.44	50.5	9.5	4	144	16	22
CEA 5502 75 9D	26.22	19.03	75.8	14.3	6	180	16	28
CEA 5502 101 9D	31.84	23.32	101	19	8	217	16	28
CEA 5503 76 9D	29.33	21.2	76.5	14.4	4	238	16	28
CEA 5503 114 9D	40.23	29.36	114.7	21.6	6	286	16	35
CEA 5503 152 9D	47.59	34.72	152.9	28.8	8	88	22	35
CEA 5504 102 9D	40.05	29.16	102.4	19.3	4	105	16	35
CEA 5504 153 9D	52.99	38.48	153.6	28.9	6	170	22	35
CEA 5504 204 9D	60.81	43.86	204.8	38.5	8	206	22	35
CEA 6301 35 9D	13.64	9.89	35	6.6	4	138	16	19
CEA 6301 52 9D	19.02	13.87	52.5	9.9	6	158	16	22
CEA 6301 70 9D	22.86	16.74	70	13.2	8	183	16	22
CEA 6301 87 9D	21.75	16.74	87	27.5	10	183	16	28
CEA 6302 71 9D	28.64	20.78	71.6	13.5	4	250	16	35
CEA 6302 107 9D	38.62	28.18	107.4	20.2	6	293	22	35
CEA 6302 143 9D	46.45	34.04	143.2	26.9	8	340	22	35
CEA 6302 178 9D	40.42	30.12	178.1	56.2	10	391	22	42
CEA 6303 108 9D	43.14	31.35	108.2	20.4	4	362	22	42
CEA 6303 162 9D	58.11	42.31	162.4	30.5	6	425	22	42
CEA 6303 215 9D	67.52	48.96	216.5	40.7	8	495	22	42
CEA 6303 269 9D	68.83	51.28	269.2	85	10	570	2×22	2×35
CEA 6304 144 9D	57.75	41.91	144.9	27.2	4	473	16	28
CEA 6304 216 9D	74.71	53.85	217.3	40.9	6	556	16	28
CEA 6304 288 9D	93.62	68.62	289.7	54.5	8	649	16	28
CEA 6304 360 9D	95.99	71.74	360.2	113.7	10	746	22	35
CEA 8001 56 9D	23.03	16.77	56.7	10.7	4	195	22	42
CEA 8001 85 9D	30.14	21.87	85	16	6	228	22	42
CEA 8001 113 9D	36.64	26.79	113.4	21.3	8	271	22	42
CEA 8001 141 9D	29.95	22.87	141	44.5	10	308	22	54
CEA 8002 115 9D	46.09	33.41	115.6	21.7	4	355	2×22	2×35
CEA 8002 173 9D	62.08	45.25	173.5	32.6	6	423	16	22
CEA 8002 230 9D	74.34	54.4	231.3	43.5	8	506	16	35
CEA 8002 288 9D	69.69	50.84	287.6	90.8	10	576	2×16	2×28
CEA 8003 174 9D	70.41	51.31	174.6	32.8	4	517	2×22	2×35
CEA 8003 261 9D	92.4	67.12	261.9	49.3	6	618	16	28
CEA 8003 347 9D	112.66	82.64	349.2	65.7	8	737	22	42
CEA 8003 434 9D	113.35	85.36	434.2	137.1	10	839	2×22	2×35

型号	风机							电加热		
	直径 (\varnothing mm)	数量	电压 (V, 50Hz)	功率 (W)	电流 (A)	风量 (m ³ /h)	射程 (m)	内芯 (W)	接水盘 (W)	总功率 (W)
CEA 5501 24 9D	550	1	3 ~ 400	770	1.7	8231	17	4 × 1280	1 × 1280	6400
CEA 5501 37 9D	550	1	3 ~ 400	770	1.7	7858	16	6 × 1280	2 × 1280	10240
CEA 5501 49 9D	550	1	3 ~ 400	770	1.7	7545	16	8 × 1280	2 × 1280	12800
CEA 5502 50 9D	550	2	3 ~ 400	1540	3.3	16538	21	4 × 2320	1 × 2320	11600
CEA 5502 75 9D	550	2	3 ~ 400	1540	3.3	15805	20	6 × 2320	2 × 2320	18560
CEA 5502 101 9D	550	2	3 ~ 400	1540	3.3	15201	19	8 × 2320	2 × 2320	23200
CEA 5503 76 9D	550	3	3 ~ 400	2310	5	24838	24	4 × 3200	1 × 3200	16000
CEA 5503 114 9D	550	3	3 ~ 400	2310	5	23753	23	6 × 3200	2 × 3200	25600
CEA 5503 152 9D	550	3	3 ~ 400	2310	5	22849	22	8 × 3200	2 × 3200	32000
CEA 5504 102 9D	550	4	3 ~ 400	3080	6.6	33147	28	4 × 4260	1 × 4260	21300
CEA 5504 153 9D	550	4	3 ~ 400	3080	6.6	31696	27	6 × 4260	2 × 4260	34080
CEA 5504 204 9D	550	4	3 ~ 400	3080	6.6	30496	26	8 × 4260	2 × 4260	42600
CEA 6301 35 9D	630	1	3 ~ 400	1100	2.2	12177	20	5 × 1510	1 × 1510	9060
CEA 6301 52 9D	630	1	3 ~ 400	1100	2.2	11812	19	7 × 1510	2 × 1510	13590
CEA 6301 70 9D	630	1	3 ~ 400	1100	2.2	11354	19	9 × 1510	2 × 1510	16610
CEA 6301 87 9D	630	1	3 ~ 400	1100	2.2	10792	18	12 × 1510	2 × 1510	21140
CEA 6302 71 9D	630	2	3 ~ 400	2200	4.4	24405	24	5 × 2740	1 × 2740	16440
CEA 6302 107 9D	630	2	3 ~ 400	2200	4.4	23733	23	7 × 2740	2 × 2740	24660
CEA 6302 143 9D	630	2	3 ~ 400	2200	4.4	22851	22	9 × 2740	2 × 2740	30140
CEA 6302 178 9D	630	2	3 ~ 400	2200	4.4	21767	21	12 × 2740	2 × 2740	38360
CEA 6303 108 9D	630	3	3 ~ 400	3300	6.6	36642	28	5 × 3800	1 × 3800	22800
CEA 6303 162 9D	630	3	3 ~ 400	3300	6.6	35653	27	7 × 3800	2 × 3800	34200
CEA 6303 215 9D	630	3	3 ~ 400	3300	6.6	34330	26	9 × 3800	2 × 3800	41800
CEA 6303 269 9D	630	3	3 ~ 400	3300	6.6	32683	25	12 × 3800	2 × 3800	53200
CEA 6304 144 9D	630	4	3 ~ 400	4400	8.8	48861	35	5 × 5060	1 × 5060	30360
CEA 6304 216 9D	630	4	3 ~ 400	4400	8.8	47609	33	7 × 5060	2 × 5060	45540
CEA 6304 288 9D	630	4	3 ~ 400	4400	8.8	45798	31	9 × 5060	2 × 5060	55660
CEA 6304 360 9D	630	4	3 ~ 400	4400	8.8	43611	29	12 × 5060	2 × 5060	70840
CEA 8001 56 9D	800	1	3 ~ 400	1600	3.5	19936	25	7 × 1700	1 × 1700	13600
CEA 8001 85 9D	800	1	3 ~ 400	1600	3.5	19067	24	10 × 1700	2 × 1700	20400
CEA 8001 113 9D	800	1	3 ~ 400	1600	3.5	18247	23	16 × 1700	2 × 1700	30600
CEA 8001 141 9D	800	1	3 ~ 400	1600	3.5	17385	22	16 × 1700	2 × 1700	30600
CEA 8002 115 9D	800	2	3 ~ 400	3200	7	39987	30	7 × 2810	1 × 2810	22480
CEA 8002 173 9D	800	2	3 ~ 400	3200	7	38339	29	10 × 2810	2 × 2810	33720
CEA 8002 230 9D	800	2	3 ~ 400	3200	7	36699	28	16 × 2810	2 × 2810	50580
CEA 8002 288 9D	800	2	3 ~ 400	3200	7	34944	27	16 × 2810	2 × 2810	50580
CEA 8003 174 9D	800	3	3 ~ 400	4800	10.5	60065	37	7 × 4420	1 × 4420	35360
CEA 8003 261 9D	800	3	3 ~ 400	4800	10.5	57571	35	10 × 4420	2 × 4420	53040
CEA 8003 347 9D	800	3	3 ~ 400	4800	10.5	55110	33	16 × 4420	2 × 4420	79560
CEA 8003 434 9D	800	3	3 ~ 400	4800	10.5	52480	31	16 × 4420	2 × 4420	79560

选配

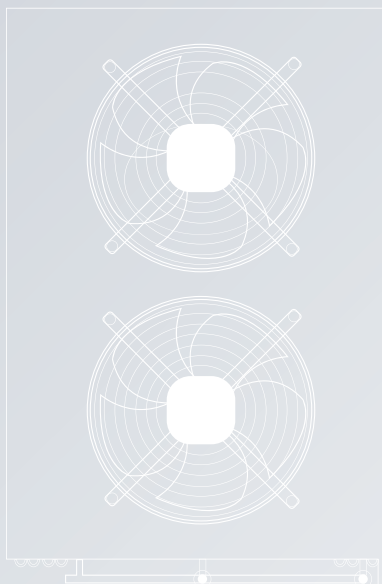
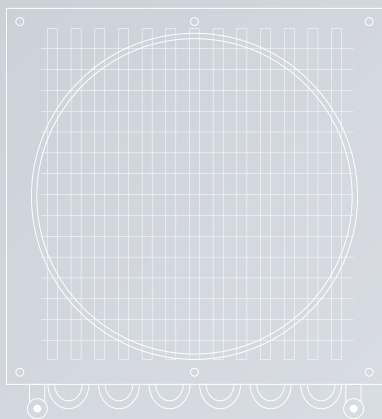
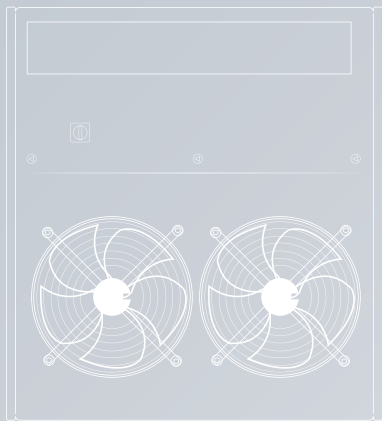
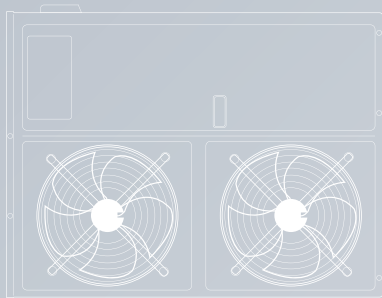

电加热

- 空气化霜
- 电化霜
- 热氟化霜
- 水化霜
- 内芯热氟化霜，接水盘电化霜
- 水化霜和电化霜



管材

- 铜
- 304 不锈钢



翅片

- 普通铝箔
- 金色铝箔



风机

- EC 风机
- 风筒电加热（仅供 500mm 及以上的风机）
- 导风筒



钣金

- 铝制白色喷涂
- 304 不锈钢



其他

- 双接水盘（低温工况推荐）
- 电化霜热保护器



CED & CED Plus 蒸发器

双出风蒸发器

CED 和 CED Plus 系列双出风蒸发器适用于中低空间高度冷库的冷冻冷藏需求，同时也能应用于工作间。

CED 和 CED Plus 的高效内芯采用铝箔和 $\varnothing 9.52\text{mm}$ 内螺纹铜管，具有较高的换热性能。所有内芯均经过清洁和 80bar 保压测试。

01 白色喷涂的铝制外壳，有较高的防腐蚀和抗震性能。

02 电化霜的电加热管套有不锈钢管，固定于翅片和接水盘内，可隔绝水蒸气，且方便维护。

03 所有电器有效接地。电线均接入防护等级 IP65 的电器盒内。

04 可使用“Unit Selector Hybrid HISPANIA”选型软件查询样册以外的工况性能。



更多需求和信息请联系 Hispania。

CED 3502 31 4LD S1 2 3

翅片材料 (空白: 铝箔, 3: 不锈钢, GF: 金色铝箔)

外壳材料 (空白: 铝, 2: 不锈钢)

盘管材料 (空白: 铜, 1: 不锈钢)

化霜 (空白: 空气, D: 电, HG: 热氟, W: 水, HGD: 热氟&电, WD: 水&电)

L: 低速, N: 高速

片距 (mm)

面积 (m²)

风机数量

风机直径 (mm)

系列

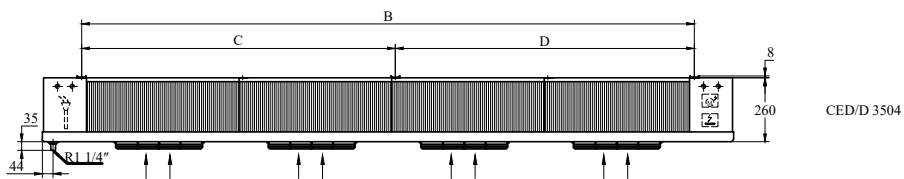
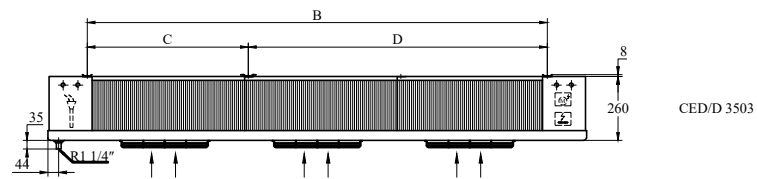
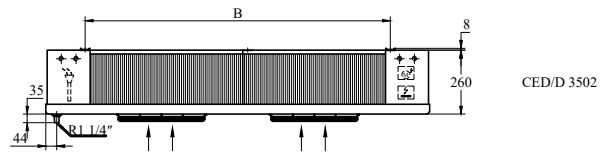
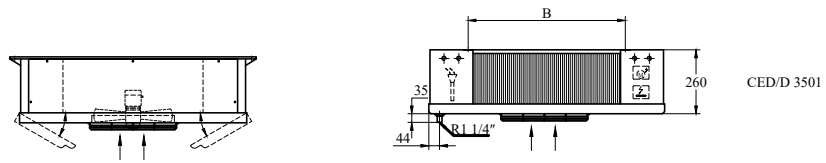
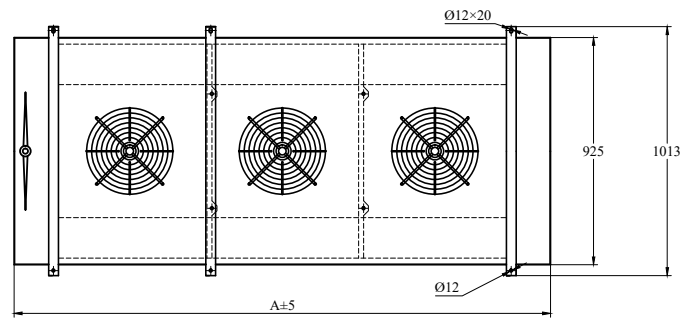

型号	外形尺寸(mm)			
	A	B	C	D
CED 3501...	963	640		
CED 3502...	1565	1242		
CED 3503...	2167	1844	640	1204
CED 3504...	2769	2446	1242	1204

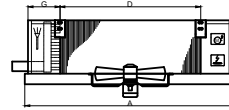
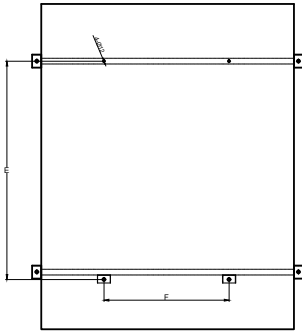
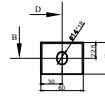
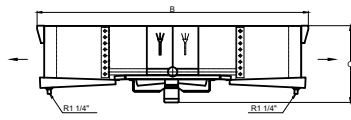

HED/D PLUS
40014501/5001/6301/8001

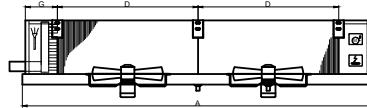

HED/D PLUS
40024502/5002/6302/8002

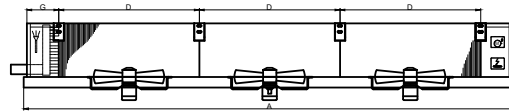

HED/D PLUS
40034503/5003/6303/8003

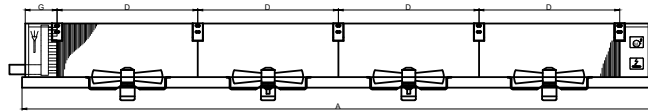

HED/D PLUS
40044504/5004/6304

型号	外形尺寸(mm)						
	A	B	C	D	E	F	G
CED Plus 4001...	1000	1390	415	600	655	565	190
CED Plus 4002...	1640	1390	415	600	1255	565	210
CED Plus 4003...	2280	1390	415	600	1855	565	230
CED Plus 4004...	2880	1390	415	600	2455	565	230
CED Plus 4501...	1200	1390	430	800	855	565	190
CED Plus 4502...	2040	1390	430	800	1655	565	210
CED Plus 4503...	2880	1390	430	800	2455	565	230
CED Plus 4504...	3680	1390	430	800	3255	565	230
CED Plus 5001...	1480	1530	430	1000	1055	565	230
CED Plus 5002...	2480	1530	430	1000	2055	565	230
CED Plus 5003...	3520	1530	430	1000	3055	565	250
CED Plus 5004...	4520	1530	430	1000	4055	565	250
CED Plus 6301...	1850	1705	570	1200	1255	745	315
CED Plus 6302...	3050	1705	570	1200	2455	745	315
CED Plus 6303...	4350	1705	570	1200	3655	745	365
CED Plus 6304...	5550	1705	570	1200	4855	745	365
CED Plus 8001...	2050	2020	750	1400	1455	1060	315
CED Plus 8002...	3450	2020	750	1400	2855	1060	315
CED Plus 8003...	4850	2020	750	1400	4255	1060	315

片距 4 mm，带电加热。库温 $\geq 0^{\circ}\text{C}$

型号	制冷量 R744 (kw)		面积 (m ²)	管容积 (dm ³)	净重 (kg)	接口尺寸 (ømm)	
	te= 0°C	te= -8°C				进	出
	DTI=10K	DTI=8K					
CED 3501 17 4LD	4.14	2.94	17.4	1.5	29.7	12	15
CED 3501 17 4ND	5.65	3.92	17.4	1.5	29.7	12	15
CED 3502 35 4LD	7.64	5.55	34.9	3.1	49.5	12	15
CED 3502 35 4ND	9.84	7.04	34.9	3.1	49.5	12	15
CED 3503 52 4LD	12.23	8.79	52.4	4.6	69.6	12	15
CED 3503 52 4ND	16.38	11.53	52.4	4.6	69.6	12	19
CED 3504 70 4LD	15.47	11.22	69.8	6.2	89.3	12	19
CED 3504 70 4ND	20.04	14.32	69.8	6.2	89.3	12	19

型号	风机							电加热	
	直径 (ø mm)	数量	电压 (V, 50Hz)	功率 (W)	电流 (A)	风量 (m ³ /h)	射程 (m)	内芯 (W)	总功率 (W)
CED 3501 17 4LD	350	1	1~230	94	0.4	1167	2 × 6	4 × 320	1280
CED 3501 17 4ND	350	1	1~230	150	0.7	1848	2 × 9	4 × 320	1280
CED 3502 35 4LD	350	2	1~230	188	0.9	2335	2 × 7	4 × 585	2340
CED 3502 35 4ND	350	2	1~230	300	1.5	3696	2 × 10	4 × 585	2340
CED 3503 52 4LD	350	3	1~230	282	1.3	3504	2 × 8	4 × 850	3400
CED 3503 52 4ND	350	3	1~230	450	2.2	5544	2 × 11	4 × 850	3400
CED 3504 70 4LD	350	4	1~230	376	1.7	4672	2 × 9	4 × 1050	4200
CED 3504 70 4ND	350	4	1~230	600	2.9	7392	2 × 12	4 × 1050	4200

片距 6 mm，带电加热。库温 $\geq -18^{\circ}\text{C}$

型号	制冷量 R744 (kw)		面积 (m ²)	管容积 (dm ³)	净重 (kg)	接口尺寸 (ømm)	
	te= -8°C	te= -25°C				进	出
	DTI=8K	DTI=7K					
CED 3501 12 6LD	3.72	2.6	11.9	1.5	29.7	12	15
CED 3501 12 6ND	4.78	3.29	11.9	1.5	29.7	12	15
CED 3502 24 6LD	7.02	5.01	23.8	3.1	49.5	12	15
CED 3502 24 6ND	8.69	6.15	23.8	3.1	49.5	12	15
CED 3503 36 6LD	11.08	7.82	35.8	4.6	69.6	12	15
CED 3503 36 6ND	14.08	9.82	35.8	4.6	69.6	12	19
CED 3504 48 6LD	14.19	10.12	47.7	6.2	89.3	12	19
CED 3504 48 6ND	17.63	12.46	47.7	6.2	89.3	12	19

型号	风机							电加热	
	直径 (ø mm)	数量	电压 (V, 50Hz)	功率 (W)	电流 (A)	风量 (m ³ /h)	射程 (m)	内芯 (W)	总功率 (W)
CED 3501 12 6LD	350	1	1-230	94	0.4	1267	2 × 6	4 × 320	1280
CED 3501 12 6ND	350	1	1-230	150	0.7	1879	2 × 9	4 × 320	1280
CED 3502 24 6LD	350	2	1-230	188	0.9	2533	2 × 7	4 × 585	2340
CED 3502 24 6ND	350	2	1-230	300	1.5	3758	2 × 10	4 × 585	2340
CED 3503 36 6LD	350	3	1-230	282	1.3	3801	2 × 8	4 × 850	3400
CED 3503 36 6ND	350	3	1-230	450	2.2	5638	2 × 11	4 × 850	3400
CED 3504 48 6LD	350	4	1-230	376	1.7	5068	2 × 9	4 × 1050	4200
CED 3504 48 6ND	350	4	1-230	600	2.9	7517	2 × 12	4 × 1050	4200

片距 4 mm，带电加热。库温 $\geq 0^{\circ}\text{C}$

型号	制冷量 R744 (kw)		面积 (m ²)	管容积 (dm ³)	净重 (kg)	接口尺寸 (ømm)	
	te= 0°C	te= -8°C				进	出
	DTI=10K	DTI=8K					
CED Plus 4001 23 4D	8.53	5.87	23.3	2.07	65.2	12	15
CED Plus 4001 34 4D	10.37	7.19	35	3.11	72.6	12	15
CED Plus 4002 46 4D	17.12	11.77	46.6	4.14	109.3	12	15
CED Plus 4002 68 4D	20.89	14.64	69.9	6.21	122.4	12	19
CED Plus 4003 68 4D	25.79	17.99	69.9	6.21	145.1	12	19
CED Plus 4003 103 4D	31.35	21.79	104.9	9.31	166.5	15	22
CED Plus 4004 91 4D	34.28	23.58	93.2	8.28	189.3	15	22
CED Plus 4004 137 4D	41.92	29.37	139.8	12.41	215	15	28
CED Plus 4501 30 4D	11.89	8.29	31.1	2.76	74.5	12	15
CED Plus 4501 46 4D	14.5	10.18	46.6	4.14	83.9	12	15
CED Plus 4502 61 4D	23.91	16.66	62.1	5.52	127.4	12	19
CED Plus 4502 91 4D	29.12	20.43	93.2	8.28	145.5	15	19
CED Plus 4503 91 4D	35.69	24.62	93.2	8.28	172	15	22
CED Plus 4503 137 4D	43.67	30.74	139.8	12.41	197.7	15	28
CED Plus 4504 122 4D	47.95	33.4	124.3	11.03	223	15	28
CED Plus 4504 182 4D	58.35	40.93	186.4	16.55	258.9	15	28
CED Plus 5001 57 4D	20.59	14.19	58.3	5.17	108.8	12	19
CED Plus 5001 76 4D	22.79	15.9	77.7	6.9	121.7	12	19
CED Plus 5002 114 4D	41.21	28.41	116.5	10.34	190	15	22
CED Plus 5002 152 4D	45.61	31.82	155.3	13.79	213.2	15	28
CED Plus 5003 171 4D	63.03	43.99	174.8	15.51	257.8	15	28
CED Plus 5003 228 4D	69.66	49.08	233	20.68	291.9	15	35
CED Plus 5004 228 4D	83.35	58.74	233	20.68	342	22	35
CED Plus 5004 304 4D	92.51	65.7	310.7	27.57	391.7	22	35
CED Plus 6301 103 4D	37.98	26.26	104.9	9.31	191.4	15	22
CED Plus 6301 137 4D	42.62	29.59	139.8	12.41	211.4	15	28
CED Plus 6302 205 4D	76.33	53.48	209.7	18.61	330	15	35
CED Plus 6302 274 4D	85.85	60.26	279.6	24.82	369.9	22	35
CED Plus 6303 308 4D	114.67	80.32	314.6	27.92	458.2	22	42
CED Plus 6303 410 4D	128.92	90.48	419.4	37.22	519.8	22	42
CED Plus 6304 410 4D	148.67	105.31	419.4	37.22	605.2	22	42
CED Plus 6304 547 4D	168.49	119.35	559.2	49.63	693.7	22	54
CED Plus 8001 160 4D	53.08	36.79	163.1	14.48	273.8	15	28
CED Plus 8001 213 4D	58.67	40.93	217.5	19.3	304.4	15	28
CED Plus 8002 319 4D	106.32	73.69	326.2	28.95	483	22	35
CED Plus 8002 426 4D	117.48	81.94	435	38.6	548	2×15	2×28
CED Plus 8003 479 4D	158.4	111.18	489.3	43.43	667.1	22	54
CED Plus 8003 638 4D	175.79	123.86	652.5	57.9	760.8	2×22	2×35

型号	风机							电加热		
	直径 (\varnothing mm)	数量	电压 (V, 50Hz)	功率 (W)	电流 (A)	风量 (m ³ /h)	射程 (m)	内芯 (W)	水盘 (W)	总功率 (W)
CED Plus 4001 23 4D	400	1	1~230	177	0.3	3082	2×5	4×750	2×750	4500
CED Plus 4001 34 4D	400	1	1~230	177	0.3	2830	2×5	4×750	4×750	6000
CED Plus 4002 46 4D	400	2	1~230	354	0.6	6163	2×6	4×1250	2×1250	7500
CED Plus 4002 68 4D	400	2	1~230	354	0.6	5657	2×6	4×1250	4×1250	10000
CED Plus 4003 68 4D	400	3	1~230	531	0.9	9241	2×8	4×1700	2×1700	10200
CED Plus 4003 103 4D	400	3	1~230	531	0.9	8488	2×7	4×1700	4×1700	13600
CED Plus 4004 91 4D	400	4	1~230	708	1.2	12326	2×9	4×2740	2×2740	16440
CED Plus 4004 137 4D	400	4	1~230	708	1.2	11314	2×8	4×2740	4×2740	21920
CED Plus 4501 30 4D	450	1	3~400	350	1.1	4438	2×7	4×730	2×730	4380
CED Plus 4501 46 4D	450	1	3~400	350	1.1	4049	2×6	4×730	4×730	5840
CED Plus 4502 61 4D	450	2	3~400	700	2.2	8875	2×8	4×1800	2×1800	10800
CED Plus 4502 91 4D	450	2	3~400	700	2.2	8097	2×7	4×1800	4×1800	14400
CED Plus 4503 91 4D	450	3	3~400	1050	3.3	13317	2×9	4×2740	2×2740	16440
CED Plus 4503 137 4D	450	3	3~400	1050	3.3	12144	2×9	4×2740	4×2740	21920
CED Plus 4504 122 4D	450	4	3~400	1400	4.4	17749	2×11	4×3390	2×3390	20340
CED Plus 4504 182 4D	450	4	3~400	1400	4.4	16194	2×10	4×3390	4×3390	27120
CED Plus 5001 57 4D	500	1	3~400	577	1.4	6328	2×8	4×1280	4×1280	10240
CED Plus 5001 76 4D	500	1	3~400	577	1.4	5860	2×8	6×1280	4×1280	12800
CED Plus 5002 114 4D	500	2	3~400	1154	2.8	12656	2×10	4×2320	4×2320	18560
CED Plus 5002 152 4D	500	2	3~400	1154	2.8	11719	2×9	6×2320	4×2320	23200
CED Plus 5003 171 4D	500	3	3~400	1731	4.1	18974	2×12	4×3200	4×3200	25600
CED Plus 5003 228 4D	500	3	3~400	1731	4.1	17572	2×11	6×3200	4×3200	32000
CED Plus 5004 228 4D	500	4	3~400	2308	5.5	25291	2×14	4×4260	4×4260	34080
CED Plus 5004 304 4D	500	4	3~400	2308	5.5	23424	2×13	6×4260	4×4260	42600
CED Plus 6301 103 4D	630	1	3~400	1118	2.3	11589	2×10	6×1250	4×1250	12500
CED Plus 6301 137 4D	630	1	3~400	1118	2.3	10848	2×10	8×1250	4×1250	15000
CED Plus 6302 205 4D	630	2	3~400	2236	4.5	23168	2×13	6×2740	4×2740	27400
CED Plus 6302 274 4D	630	2	3~400	2236	4.5	21690	2×12	8×2740	4×2740	32880
CED Plus 6303 308 4D	630	3	3~400	3354	6.8	34752	2×15	6×3800	4×3800	38000
CED Plus 6303 410 4D	630	3	3~400	3354	6.8	32535	2×14	8×3800	4×3800	45600
CED Plus 6304 410 4D	630	4	3~400	4472	9	46327	2×18	6×5060	4×5060	50600
CED Plus 6304 547 4D	630	4	3~400	4472	9	43373	2×17	8×5060	4×5060	60720
CED Plus 8001 160 4D	800	1	3~400	1369	3.4	14957	2×11	8×1700	4×1700	20400
CED Plus 8001 213 4D	800	1	3~400	1369	3.4	14033	2×10	10×1700	4×1700	23800
CED Plus 8002 319 4D	800	2	3~400	2738	6.7	29913	2×13	8×2810	4×2810	33720
CED Plus 8002 426 4D	800	2	3~400	2738	6.7	28065	2×12	10×2810	4×2810	39340
CED Plus 8003 479 4D	800	3	3~400	4107	10.1	44860	2×16	8×4420	4×4420	53040
CED Plus 8003 638 4D	800	3	3~400	4107	10.1	42089	2×15	10×4420	4×4420	61880

片距 6 mm，带电加热。库温 $\geq -18^{\circ}\text{C}$

型号	制冷量 R744 (kw)		面积 (m ²)	管容积 (dm ³)	净重 (kg)	接口尺寸 (ømm)	
	te= -8°C	te= -25°C				进	出
	DTI=8K	DTI=7K					
CED Plus 4001 16 6D	4.9	3.58	15.9	2.07	64.4	12	15
CED Plus 4001 24 6D	6.29	4.62	23.9	3.11	71.3	12	15
CED Plus 4002 31 6D	9.82	7.17	31.8	4.14	107.6	12	15
CED Plus 4002 47 6D	12.91	9.52	47.8	6.21	119.8	12	19
CED Plus 4003 47 6D	15.13	11.08	47.8	6.21	142.5	12	19
CED Plus 4003 71 6D	19.08	14.06	71.6	9.31	162.6	15	22
CED Plus 4004 63 6D	19.65	14.35	63.7	8.28	185.8	15	22
CED Plus 4004 94 6D	25.87	19.09	95.5	12.41	209.9	15	28
CED Plus 4501 21 6D	7.01	5.15	21.2	2.76	73.3	12	15
CED Plus 4501 31 6D	8.94	6.59	31.8	4.14	82.2	12	15
CED Plus 4502 42 6D	14.07	10.35	42.4	5.52	125.1	12	19
CED Plus 4502 63 6D	17.93	13.23	63.7	8.28	142	15	19
CED Plus 4503 63 6D	20.66	15.21	63.7	8.28	168.7	15	22
CED Plus 4503 94 6D	27.05	19.98	95.5	12.41	192.8	15	28
CED Plus 4504 84 6D	28.18	20.74	84.9	11.03	218.6	15	28
CED Plus 4504 125 6D	35.91	26.51	127.3	16.55	252.2	15	28
CED Plus 5001 39 6D	12.27	9.12	39.8	5.17	106.5	12	19
CED Plus 5001 52 6D	14.2	10.51	53.1	6.9	118.8	12	19
CED Plus 5002 78 6D	24.55	18.25	79.6	10.34	185.7	15	22
CED Plus 5002 105 6D	28.42	21.02	106.1	13.79	207.4	15	28
CED Plus 5003 118 6D	38.28	28.28	119.4	15.51	251.3	15	28
CED Plus 5003 157 6D	44.17	32.81	159.2	20.68	283.3	15	35
CED Plus 5004 157 6D	51.49	38.06	159.2	20.68	333.3	22	35
CED Plus 5004 209 6D	59.49	44.23	212.2	27.57	380.2	22	35
CED Plus 6301 71 6D	22.64	16.63	71.6	9.31	187.5	15	22
CED Plus 6301 94 6D	26.36	19.48	95.5	12.41	206.3	15	28
CED Plus 6302 141 6D	46.51	34.25	143.3	18.61	322.2	15	35
CED Plus 6302 188 6D	54.1	40.1	191	24.82	359.5	22	35
CED Plus 6303 212 6D	69.83	51.45	214.9	27.92	446.5	22	42
CED Plus 6303 282 6D	81.22	60.21	286.5	37.22	504.3	22	42
CED Plus 6304 282 6D	92.51	67.88	286.5	37.22	589.7	22	42
CED Plus 6304 376 6D	108	79.82	382	49.63	673	22	54
CED Plus 8001 110 6D	31.83	23.35	111.4	14.48	267.8	15	28
CED Plus 8001 146 6D	36.85	27.19	148.6	19.3	296.3	15	28
CED Plus 8002 220 6D	63.73	46.77	222.8	28.95	470.8	22	35
CED Plus 8002 293 6D	73.74	54.43	297.1	38.6	531.7	2×15	2×28
CED Plus 8003 329 6D	97.07	71.32	334.3	43.43	649	22	54
CED Plus 8003 439 6D	112.42	83.09	445.7	57.9	736.6	2×22	2×35

型号	风机							电加热		
	直径 (\varnothing mm)	数量	电压 (V, 50Hz)	功率 (W)	电流 (A)	风量 (m ³ /h)	射程 (m)	内芯 (W)	水盘 (W)	总功率 (W)
CED Plus 4001 16 6D	400	1	1~230	177	0.3	3175	2×6	4×750	2×750	4500
CED Plus 4001 24 6D	400	1	1~230	177	0.3	2976	2×5	4×750	4×750	6000
CED Plus 4002 31 6D	400	2	1~230	354	0.6	6349	2×7	4×1250	2×1250	7500
CED Plus 4002 47 6D	400	2	1~230	354	0.6	5949	2×6	4×1250	4×1250	10000
CED Plus 4003 47 6D	400	3	1~230	531	0.9	9520	2×8	4×1700	2×1700	10200
CED Plus 4003 71 6D	400	3	1~230	531	0.9	8925	2×7	4×1700	4×1700	13600
CED Plus 4004 63 6D	400	4	1~230	708	1.2	12697	2×9	4×2740	2×2740	16440
CED Plus 4004 94 6D	400	4	1~230	708	1.2	11897	2×9	4×2740	4×2740	21920
CED Plus 4501 21 6D	450	1	3~400	350	1.1	4636	2×7	4×730	2×730	4380
CED Plus 4501 31 6D	450	1	3~400	350	1.1	4265	2×6	4×730	4×730	5840
CED Plus 4502 42 6D	450	2	3~400	700	2.2	9272	2×8	4×1800	2×1800	10800
CED Plus 4502 63 6D	450	2	3~400	700	2.2	8529	2×8	4×1800	4×1800	14400
CED Plus 4503 63 6D	450	3	3~400	1050	3.3	13914	2×10	4×2740	2×2740	16440
CED Plus 4503 94 6D	450	3	3~400	1050	3.3	12791	2×9	4×2740	4×2740	21920
CED Plus 4504 84 6D	450	4	3~400	1400	4.4	18543	2×12	4×3390	2×3390	20340
CED Plus 4504 125 6D	450	4	3~400	1400	4.4	17057	2×11	4×3390	4×3390	27120
CED Plus 5001 39 6D	500	1	3~400	577	1.4	6661	2×9	4×1280	4×1280	10240
CED Plus 5001 52 6D	500	1	3~400	577	1.4	6211	2×8	6×1280	4×1280	12800
CED Plus 5002 78 6D	500	2	3~400	1154	2.8	13321	2×10	4×2320	4×2320	18560
CED Plus 5002 105 6D	500	2	3~400	1154	2.8	12421	2×10	6×2320	4×2320	23200
CED Plus 5003 118 6D	500	3	3~400	1731	4.1	19970	2×12	4×3200	4×3200	25600
CED Plus 5003 157 6D	500	3	3~400	1731	4.1	18622	2×12	6×3200	4×3200	32000
CED Plus 5004 157 6D	500	4	3~400	2308	5.5	26617	2×15	4×4260	4×4260	34080
CED Plus 5004 209 6D	500	4	3~400	2308	5.5	24823	2×14	6×4260	4×4260	42600
CED Plus 6301 71 6D	630	1	3~400	1118	2.3	12099	2×11	6×1250	4×1250	12500
CED Plus 6301 94 6D	630	1	3~400	1118	2.3	11406	2×10	8×1250	4×1250	15000
CED Plus 6302 141 6D	630	2	3~400	2236	4.5	24186	2×13	6×2740	4×2740	27400
CED Plus 6302 188 6D	630	2	3~400	2236	4.5	22804	2×12	8×2740	4×2740	32880
CED Plus 6303 212 6D	630	3	3~400	3354	6.8	36279	2×16	6×3800	4×3800	38000
CED Plus 6303 282 6D	630	3	3~400	3354	6.8	34205	2×15	8×3800	4×3800	45600
CED Plus 6304 282 6D	630	4	3~400	4472	9	48361	2×19	6×5060	4×5060	50600
CED Plus 6304 376 6D	630	4	3~400	4472	9	45599	2×18	8×5060	4×5060	60720
CED Plus 8001 110 6D	800	1	3~400	1369	3.4	15493	2×11	8×1700	4×1700	20400
CED Plus 8001 146 6D	800	1	3~400	1369	3.4	14757	2×11	10×1700	4×1700	23800
CED Plus 8002 220 6D	800	2	3~400	2738	6.7	30986	2×14	8×2810	4×2810	33720
CED Plus 8002 293 6D	800	2	3~400	2738	6.7	29514	2×13	10×2810	4×2810	39340
CED Plus 8003 329 6D	800	3	3~400	4107	10.1	46466	2×16	8×4420	4×4420	53040
CED Plus 8003 439 6D	800	3	3~400	4107	10.1	44260	2×16	10×4420	4×4420	61880

片距 9 mm，带电加热。库温 $\geq -35^{\circ}\text{C}$

型号	制冷量 R744 (kw)		面积 (m ²)	管容积 (dm ³)	净重 (kg)	接口尺寸 (ømm)	
	te= -8°C	te= -25°C				进	出
	DTI=8K	DTI=7K					
CED Plus 4001 11 9D	3.94	2.86	11	2.07	63.2	12	15
CED Plus 4001 16 9D	5.25	3.82	16.5	3.11	69.7	12	15
CED Plus 4002 22 9D	7.89	5.72	22	4.14	105.4	12	15
CED Plus 4002 33 9D	10.83	7.9	33	6.21	116.5	12	19
CED Plus 4003 33 9D	12.23	8.89	33	6.21	139.2	12	19
CED Plus 4003 49 9D	15.94	11.62	49.5	9.31	157.8	15	22
CED Plus 4004 44 9D	15.8	11.45	44	8.28	181.5	15	22
CED Plus 4004 66 9D	21.7	15.84	66	12.41	203.3	15	28
CED Plus 4501 15 9D	5.69	4.14	14.7	2.76	71.8	12	15
CED Plus 4501 22 9D	7.5	5.5	22	4.14	80	12	15
CED Plus 4502 29 9D	11.4	8.3	29.3	5.52	122.2	12	19
CED Plus 4502 44 9D	15.03	11.02	44	8.28	137.7	15	19
CED Plus 4503 44 9D	16.68	12.1	44	8.28	164.4	15	22
CED Plus 4503 66 9D	22.72	16.68	66	12.41	186.2	15	28
CED Plus 4504 58 9D	22.82	16.62	58.6	11.03	212.9	15	28
CED Plus 4504 88 9D	30.09	22.08	88	16.55	243.6	15	28
CED Plus 5001 27 9D	10.19	7.5	27.5	5.17	103.9	12	19
CED Plus 5001 37 9D	12.15	8.91	36.6	6.9	115.2	12	19
CED Plus 5002 55 9D	20.39	15.02	55	10.34	180.3	15	22
CED Plus 5002 73 9D	24.3	17.84	73.3	13.79	200.2	15	28
CED Plus 5003 82 9D	31.92	23.41	82.5	15.51	243.2	15	28
CED Plus 5003 109 9D	37.95	27.96	109.9	20.68	272.5	15	35
CED Plus 5004 109 9D	43.18	31.74	109.9	20.68	322.6	22	35
CED Plus 5004 146 9D	51.39	37.9	146.6	27.57	365.8	22	35
CED Plus 6301 49 9D	18.69	13.59	49.5	9.31	182.6	15	22
CED Plus 6301 66 9D	22.47	16.46	66	12.41	199.7	15	28
CED Plus 6302 98 9D	38.61	28.2	98.9	18.61	312.4	15	35
CED Plus 6302 131 9D	46.38	34.1	131.9	24.82	346.5	22	35
CED Plus 6303 148 9D	57.96	42.34	148.4	27.92	432	22	42
CED Plus 6303 197 9D	69.61	51.18	197.9	37.22	484.9	22	42
CED Plus 6304 197 9D	77.49	56.57	197.9	37.22	570.2	22	42
CED Plus 6304 263 9D	93.24	68.55	263.9	49.63	647.1	22	54
CED Plus 8001 77 9D	26.4	19.23	77	14.48	260.2	15	28
CED Plus 8001 102 9D	31.51	23.07	102.6	19.3	286.2	15	28
CED Plus 8002 153 9D	52.83	38.49	153.9	28.95	455.8	22	35
CED Plus 8002 204 9D	63.06	46.18	205.2	38.6	511.7	2×15	2×28
CED Plus 8003 230 9D	81.08	59.24	230.9	43.43	626.3	22	54
CED Plus 8003 306 9D	96.78	70.95	307.8	57.9	706.3	2×22	2×35

型号	风机							电加热		
	直径 (\varnothing mm)	数量	电压 (V, 50Hz)	功率 (W)	电流 (A)	风量 (m ³ /h)	射程 (m)	内芯 (W)	水盘 (W)	总功率 (W)
CED Plus 4001 11 9D	400	1	1~230	177	0.3	3257	2×6	4×750	2×750	4500
CED Plus 4001 16 9D	400	1	1~230	177	0.3	3093	2×5	4×750	4×750	6000
CED Plus 4002 22 9D	400	2	1~230	354	0.6	6514	2×7	4×1250	2×1250	7500
CED Plus 4002 33 9D	400	2	1~230	354	0.6	6183	2×6	4×1250	4×1250	10000
CED Plus 4003 33 9D	400	3	1~230	531	0.9	9767	2×8	4×1700	2×1700	10200
CED Plus 4003 49 9D	400	3	1~230	531	0.9	9276	2×8	4×1700	4×1700	13600
CED Plus 4004 44 9D	400	4	1~230	708	1.2	13027	2×10	4×2740	2×2740	16440
CED Plus 4004 66 9D	400	4	1~230	708	1.2	12365	2×9	4×2740	4×2740	21920
CED Plus 4501 15 9D	450	1	3~400	350	1.1	4802	2×7	4×730	2×730	4380
CED Plus 4501 22 9D	450	1	3~400	350	1.1	4458	2×7	4×730	4×730	5840
CED Plus 4502 29 9D	450	2	3~400	700	2.2	9603	2×8	4×1800	2×1800	10800
CED Plus 4502 44 9D	450	2	3~400	700	2.2	8915	2×8	4×1800	4×1800	14400
CED Plus 4503 44 9D	450	3	3~400	1050	3.3	14408	2×10	4×2740	2×2740	16440
CED Plus 4503 66 9D	450	3	3~400	1050	3.3	13371	2×9	4×2740	4×2740	21920
CED Plus 4504 58 9D	450	4	3~400	1400	4.4	19205	2×12	4×3390	2×3390	20340
CED Plus 4504 88 9D	450	4	3~400	1400	4.4	17830	2×11	4×3390	4×3390	27120
CED Plus 5001 27 9D	500	1	3~400	577	1.4	6973	2×9	4×1280	4×1280	10240
CED Plus 5001 37 9D	500	1	3~400	577	1.4	6550	2×9	6×1280	4×1280	12800
CED Plus 5002 55 9D	500	2	3~400	1154	2.8	13945	2×11	4×2320	4×2320	18560
CED Plus 5002 73 9D	500	2	3~400	1154	2.8	13100	2×10	6×2320	4×2320	23200
CED Plus 5003 82 9D	500	3	3~400	1731	4.1	20904	2×13	4×3200	4×3200	25600
CED Plus 5003 109 9D	500	3	3~400	1731	4.1	19638	2×12	6×3200	4×3200	32000
CED Plus 5004 109 9D	500	4	3~400	2308	5.5	27862	2×15	4×4260	4×4260	34080
CED Plus 5004 146 9D	500	4	3~400	2308	5.5	26177	2×15	6×4260	4×4260	42600
CED Plus 6301 49 9D	630	1	3~400	1118	2.3	12490	2×11	6×1250	4×1250	12500
CED Plus 6301 66 9D	630	1	3~400	1118	2.3	11929	2×11	8×1250	4×1250	15000
CED Plus 6302 98 9D	630	2	3~400	2236	4.5	24971	2×13	6×2740	4×2740	27400
CED Plus 6302 131 9D	630	2	3~400	2236	4.5	23849	2×13	8×2740	4×2740	32880
CED Plus 6303 148 9D	630	3	3~400	3354	6.8	37457	2×16	6×3800	4×3800	38000
CED Plus 6303 197 9D	630	3	3~400	3354	6.8	35773	2×15	8×3800	4×3800	45600
CED Plus 6304 197 9D	630	4	3~400	4472	9	49934	2×19	6×5060	4×5060	50600
CED Plus 6304 263 9D	630	4	3~400	4472	9	47687	2×18	8×5060	4×5060	60720
CED Plus 8001 77 9D	800	1	3~400	1369	3.4	15974	2×12	8×1700	4×1700	20400
CED Plus 8001 102 9D	800	1	3~400	1369	3.4	15319	2×11	10×1700	4×1700	23800
CED Plus 8002 153 9D	800	2	3~400	2738	6.7	31947	2×14	8×2810	4×2810	33720
CED Plus 8002 204 9D	800	2	3~400	2738	6.7	30637	2×13	10×2810	4×2810	39340
CED Plus 8003 230 9D	800	3	3~400	4107	10.1	47907	2×17	8×4420	4×4420	53040
CED Plus 8003 306 9D	800	3	3~400	4107	10.1	45944	2×16	10×4420	4×4420	61880

选配



电加热

- 空气化霜
- 电化霜
- 热氟化霜
- 水化霜
- 内芯热氟化霜，接水盘电化霜
- 水化霜和电化霜



管材

- 铜
- 304 不锈钢



翅片

- 普通铝箔
- 金色铝箔



风机

- EC 风机



钣金

- 铝制白色喷涂
- 304 不锈钢



其他

- 电化霜热保护器

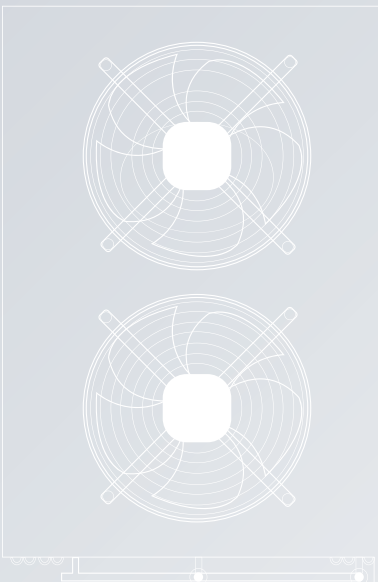
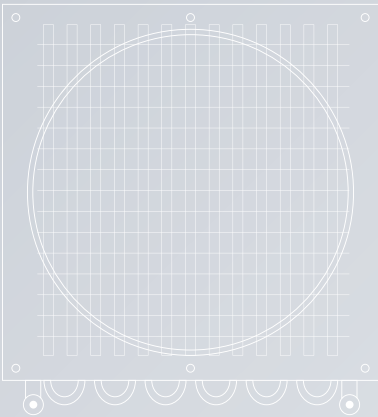
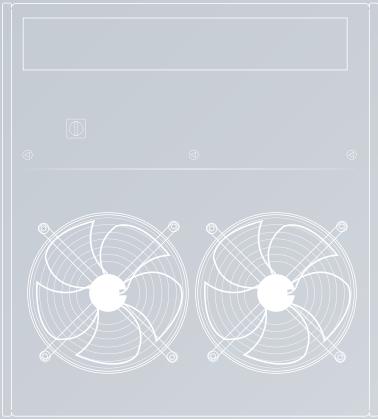
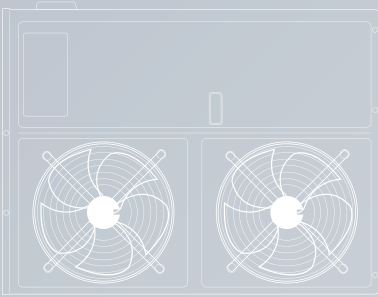

业务范围



- 中国
- 智利
- 以色列
- 西班牙
- 哥伦比亚
- 澳大利亚
- 墨西哥
- 泰国
- 英国
- 北马其顿
- 新西兰
- 阿尔及利亚
- 乌克兰
- 马来西亚
- 波兰
- 秘鲁
- 乌拉圭
- 俄罗斯
- 匈牙利
- 巴拿马
- 保加利亚
- 印度
- 厄瓜多尔
- 美国
- 也门
- 法国
- 马耳他
- 沙特阿拉伯
- 加蓬
- 萨尔瓦多
- 黎巴嫩
- 土耳其
- 多米尼加
- 阿根廷
- 叙利亚
- 意大利
- 委内瑞拉
- 新加坡
- 马达加斯加
- 迪拜
- 乌兹别克斯坦
- 哥斯达黎加
- 菲律宾
- 洪都拉斯
- 塞浦路斯
- 中国台湾
- 加纳
- 约旦
- 马尔代夫
- 卡塔尔
- 比利时





泰州伊士班尼亚
制冷设备有限公司



地址

江苏省泰州经济开发区高新技术园标准厂房B区10号



电话:

0523-80805003



邮箱:

taz39528116@126.com | 1367297073@qq.com | tzwdc@126.com

www.hispaniacorp.com

传真: 0523-80805666